

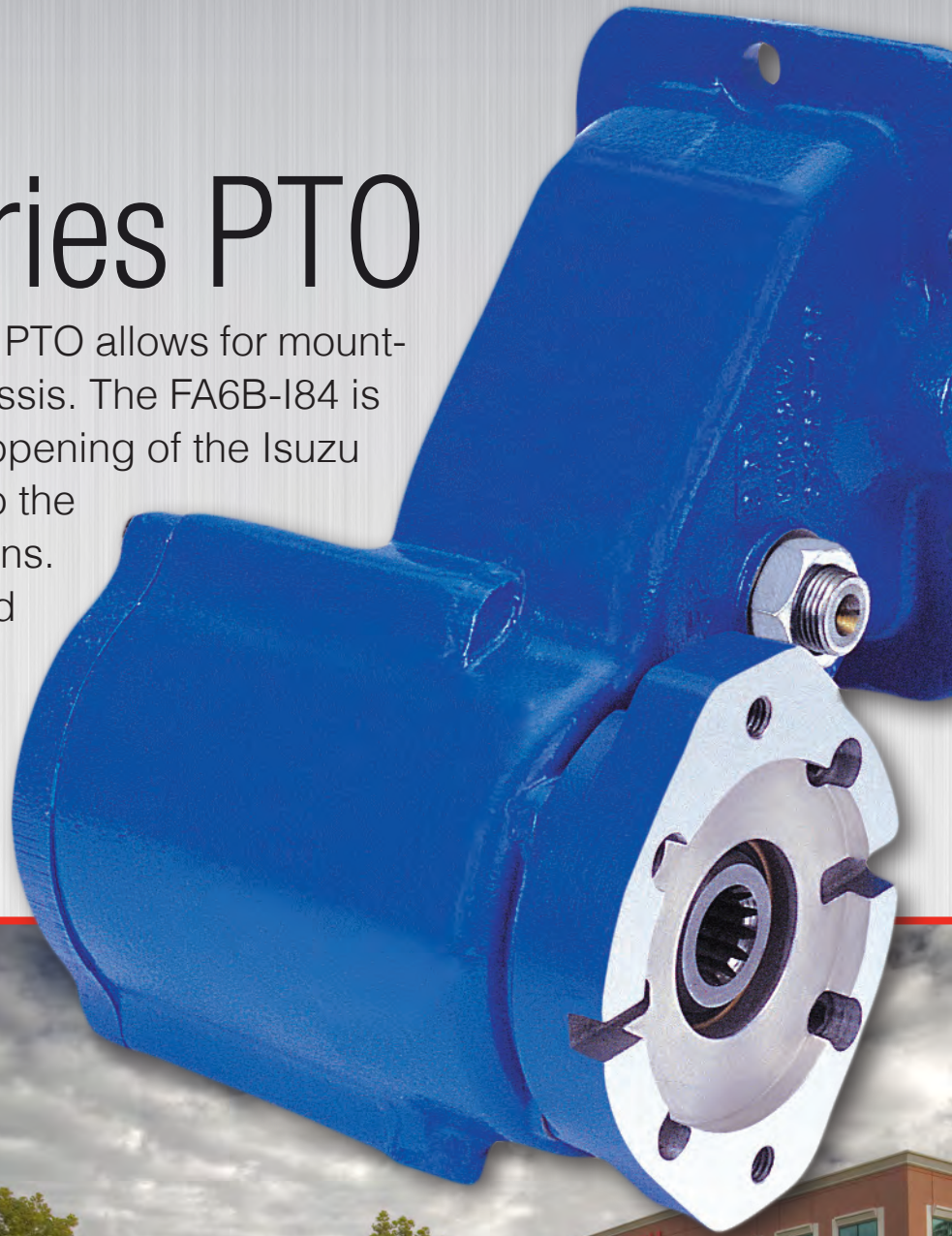

FA6B Series PTO

Muncie's new FA6B Series PTO allows for mounting on a narrow frame chassis. The FA6B-I84 is designed for the Leftside opening of the Isuzu A460 but will also mount to the standard I84 applications. The FA6B-A67 is designed for the leftside opening on Allison 1000/2000 series transmissions.



Benefits and Technical Information

- Compact Design
- Input Gear for the 2011 Isuzu NPR EcoMax chassis with A460 Transmission
- Allow installation on narrow frame rail chassis
- Clutch Shift PTO
- Exclusively for Automatic Transmissions
- Leftside Opening Only



MODEL NUMBER CONSTRUCTION

FA 6B - I84 06 - H 3 B X

PTO TYPE

Clutch Shift

MOUNTING

Clutch Shift

TRANS. GEAR

Aisin - 8.46P 20PA Spur — I84

Allison - 6.86P 20PA Spur — A67

RATIO

06 = 0.62

SPECIAL FEATURES

X — None

OUTPUT TYPE

B — 1-1/4" Rd. 5/16" KW

Q — 7/8"-13T Spl 2-Bolt "A"

T — 3/4"-11T Spl 2-Bolt "A"

R — 5/8"-9T Spl 2-Bolt "A"

ASSEMBLY ARRANGEMENT

3

SHIFT TYPE

H — Electric/Hydraulic 12V

FA6B PTO APPLICATIONS

AISIN TRANSMISSIONS

FA6B-I8406-H3BX	A460 AISIN-3	136% OPP Rotation	81. lb.Ft.
FA6B-I8406-H3BX	A465 AISIN-2	145% OPP Rotation	75. lb.Ft.
FA6B-I8406-H3BX	A445 AISIN-1	123% OPP Rotation	88. lb.Ft.

ALLISON TRANSMISSIONS

FA6B-A6706-H3BX	1000/2000 ALLI-9	179% OPP Rotation	127. lb.Ft.
-----------------	------------------	-------------------	-------------

FA6B PTO DIMENSIONS INCHES (MM)

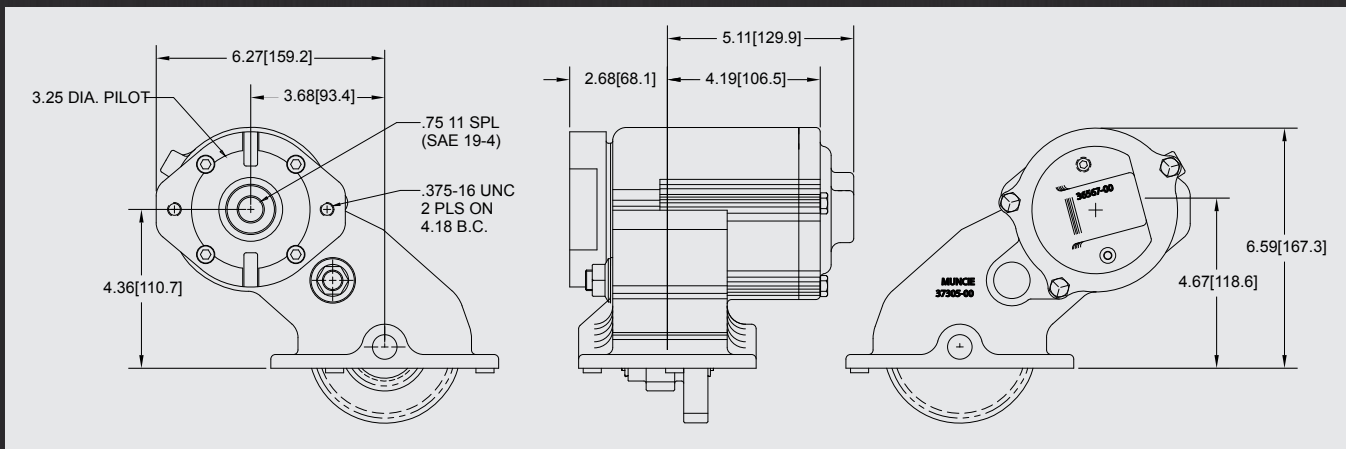

Muncie Power Products, Inc. Member of the Interpump Hydraulics Group
 General Offices and Distribution Center • P.O. Box 548 • Muncie, IN 47308-0548
 (765) 284-7721 • FAX (765) 284-6991 • E-mail info@munciepower.com
 Web site <http://www.munciepower.com>

Drive Products, Inc., Toronto, Exclusive Agents for Canada, ISO Certified by an Accredited Registrar

