



GB Series Front Mount Gear Box

More speed ratios for heavy duty equipment.

Muncie's crankshaft drive GB Series Gearboxes give you a wide variety of front drive options. More speed ratios, shift options including the Lectra-Shift, and Forward and Reverse options are available. The Muncie GB Series is lighter, quieter, and is available with more options than ever before.



MODEL NUMBER CONSTRUCTION

GB 10 - U68 06 - A 1 K X

PTO Type

GB - Gearbox

Design No.

- 10 - SG & TG
- 30 - SG & RL
- 40 - SG & RG
- 60 - SG & CS

Gear Type

- U60 - 6P20° Spur
- U68 - 6P or 6/8P Spur

Speed Ratio Range

Series/Ratio	% Eng	HP*	Torque	Rotation
TG/06	59	42	220 Lb-Ft	Same as input
TG/07	69	36	190 Lb-Ft	Same as input
TG/09	88	29	150 Lb-Ft	Same as input
RL/05	52	42	200 Lb-Ft	Fwd & Rev
RG/13	138/110	22	115 Lb-Ft	Opp/Same
CS6/07	70	35	185 Lb-Ft	Same as input

* Intermittant Duty Rated @ 1000 RPM

Special Features

X - None

Output Shaft

- B - 1-1/4 Rd. 5/16 Key (All)
- K - SAE "B" Pump Flange (GB10,60)
- F - SAE "A" Pump Flange (GB10)
- G - Special Pump Flange (GB10,60)
- L - SAE "B" Pump Flange (GB10)
- M - SAE "A" Pump Flange (GB10)
- N - Special Pump Flange (GB10)
- Q - SAE "A" Pump Flange (GB10,60)
- R - SAE "A" Pump Flange (GB10)
- S - SAE "B" Pump Flange (GB10,60)

** Refer to QR catalog for detailed description.

Assembly Arrangements

- 1 - Input/Output same
- 2 - Input/Output opposite

Shift Type

- X - None
- C - Cable
- L - Lever
- A - Manual Air
- E - Electric Air 12V
- F - Electric Air 24V
- S - Lectra-Shift (GB10)

GB SERIES FRONT MOUNT GEAR BOX MOUNTING DIMENSIONS

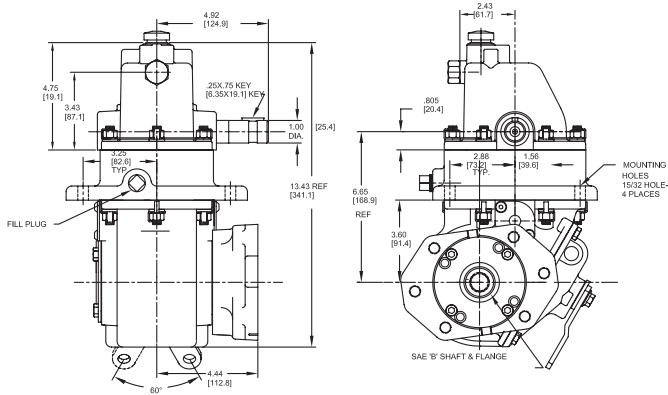

GB10 • TG SERIES

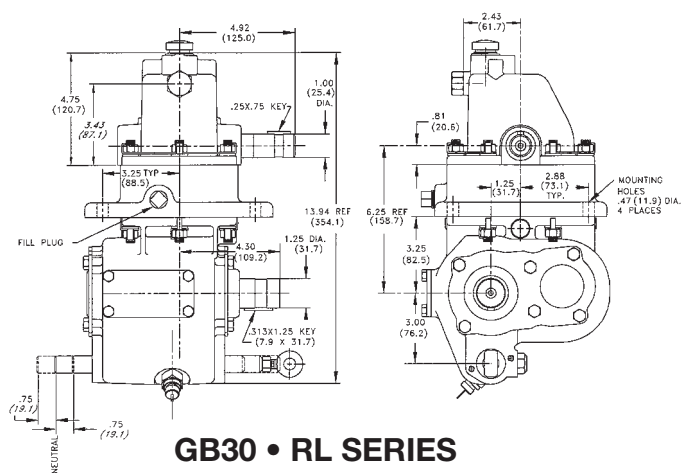

GB30 • RL SERIES

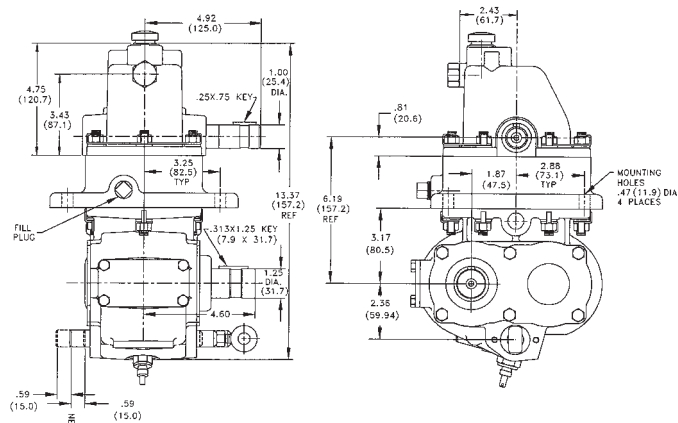

GB40 • RG SERIES

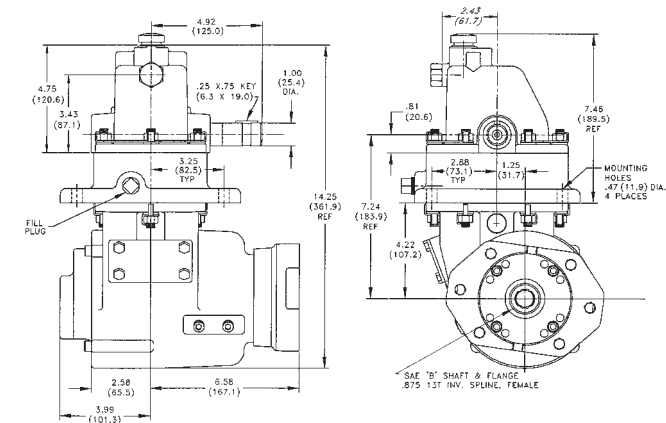

GB60 • CLUTCH SHIFT

MAJOR PARTS LIST

1. Single Gear Top Section: SG6S-U6810-X*IX
(*GB60 = 1 *All Others = 2)
2. Assembly Mounting Plate: 29M42213
3. Breather Assembly: 44T35868
Apply pipe sealant and install until tight.
4. Multiple Gear Section: GB10 — TG6S-U68**-*2*X
GB30 — RL6D-U6805-*2BX
GB40 — RG6D-U6813-*2BX
GB60 — CS6S-U6807-*3*X
5. Stud Kit: 20MK6623B — GB10 & 60
20MK6625B — GB30 & 40
(also requires 25M60200)
Installation torque value = 35 ft. lbs.
6. Fill Plug: 25M50014
Apply pipe sealant and install until tight.

ENGAGEMENT

Engine must be **OFF** for both Engagement and Disengagement of GB10, GB30 and GB40.

Engine must be at **IDLE** for engagement and disengagement of GB60.

SPECIFICATIONS

- Oil Type RequiredSAE 50W
- Oil Capacity3 Pints*
*Exact amount varies with model.
- Approximate Weight45 Lbs.
- Maximum Pump Capacity Weight.....42 Lbs.



MP84-04 (Rev. 7-06) Printed in the U.S.A.
© Muncie Power Products, Inc. 2006

Muncie Power Products, Inc. Member of the Interpump Hydraulics Group
General Offices and Distribution Center • P.O. Box 548 • Muncie, IN 47308-0548
(765) 284-7721 • FAX(765) 284-6991 • E-mail info@munciepower.com
Web site http://www.munciepower.com

Drive Products, Exclusive Agents for Canada, ISO Certified by an Accredited Registrar

