

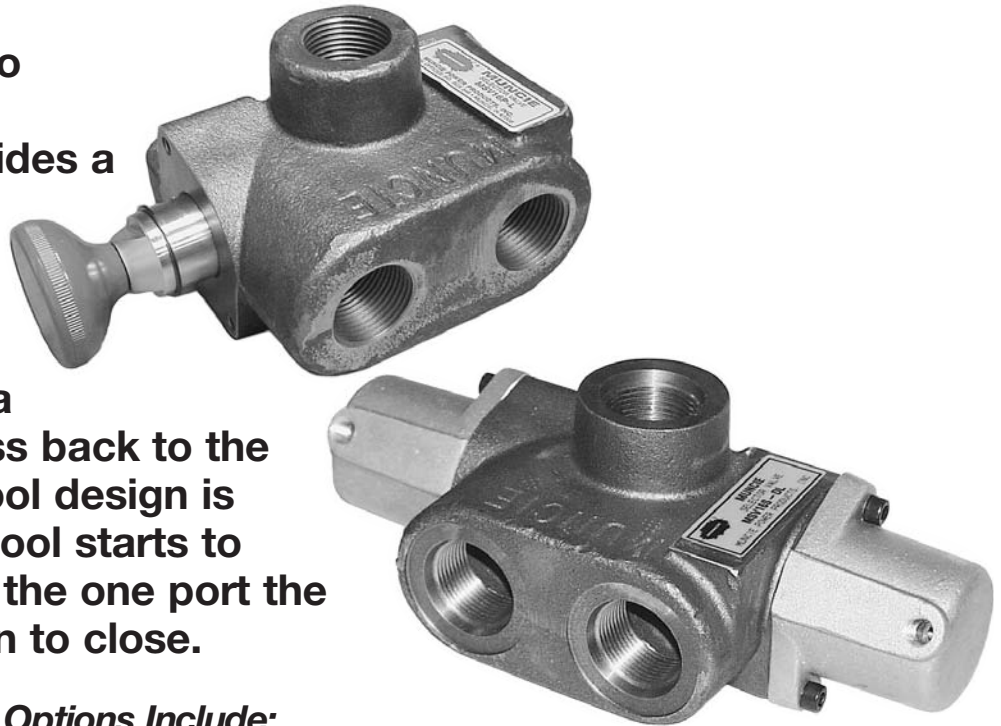

MSV SERIES TWO POSITION SELECTOR VALVE

The MSV Series two position two way selector valve provides a simple means of directing oil flow into two separate hydraulic circuits or can be used as a low pressure bypass back to the reservoir. Valve spool design is such that as the spool starts to move and open up the one port the other port will begin to close.



Standard Features and Options Include:

- High grade cast iron body
- Chrome plated spool
- Integral mounting flange interchangeable with existing competitive product
- Optional pipe or straight thread ports
- Optional integral air shaft
- Shifter controls are universal and fit either end of spool

Technical Data:

Flow Capacity:	60 GPM (227 LPM) Nominal, 90 GPM (341 LPM) Max.
Working Pressure:	2000 PSI (138 BAR) [N.P.T.], 3000 PSI (207 BAR) [Straight Thread]
Temperature:	-20°F (29°C) to 200°F (93°C)
Seal Type:	VITON
Approx. Weight:	11.6 Lbs. (5.3 Kg.)

Model Number Construction:

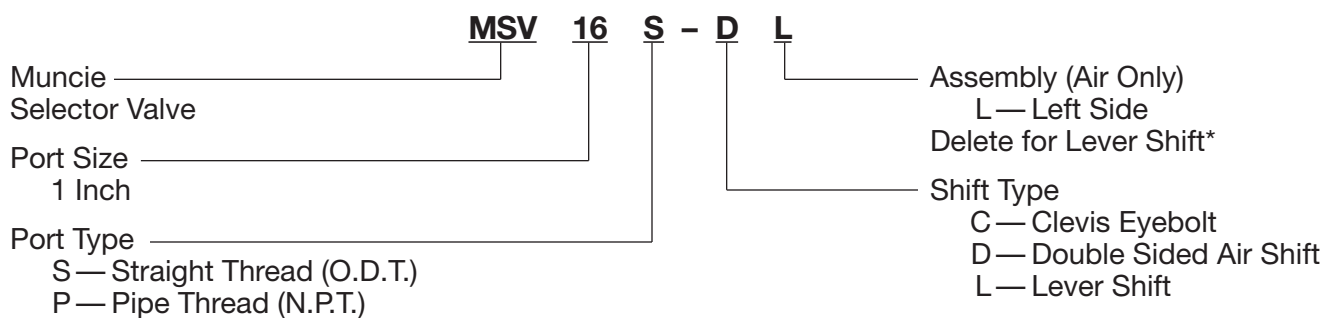

* Shift knob is shipped loose in box for installation on either end of spool.

Dimensional Data: In inches (mm)

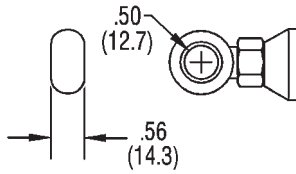

CLEVIS EYEBOLT

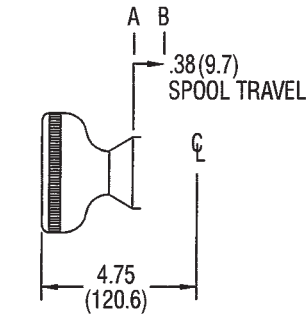

LEVERSHIFT KNOB

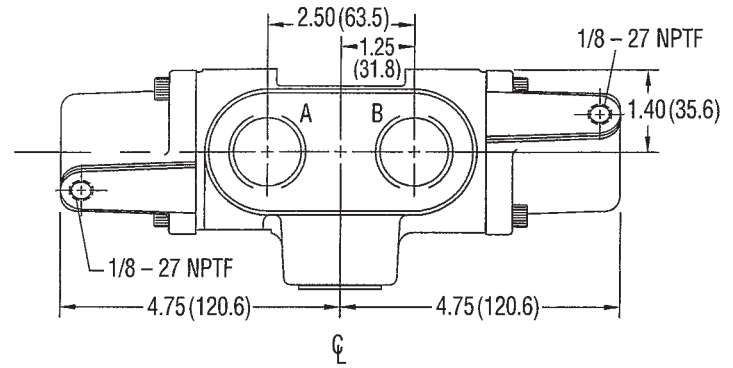

DOUBLE SIDED AIR SHIFT

CLEVIS PIN KITS

85 SERIES CABLE
(1/4 - 28 UNF)
85CLK-500

165 SERIES CABLE
(5/16 - 24 UNF)
165CLK-500

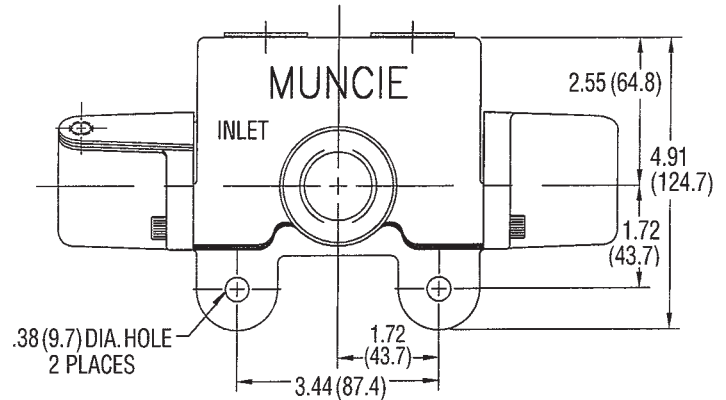
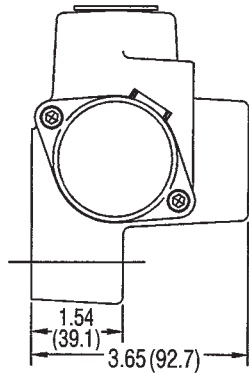

Optional Manual Air Shift Activation Kit use part number 48T38051.

Other Control Valves:

**V20 Series
Directional
Control Valve**



Our stackable design allows flexibility to meet your needs. A large variety of spool types and action controls, along with a wide range of port options are available.

Max. Flow - 30 GPM (114 LPM)
Max. Pressure - 3500 PSI (241 BAR)
Ports - SAE or N.P.T.
Circuit - Parallel

**PFD-30
Priority Flow
Divider**

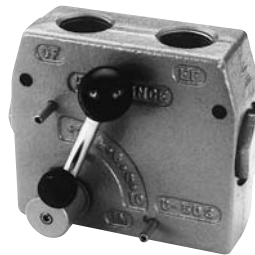

Priority Flow Divider valve provides simultaneous flow for two separate hydraulic circuits from a single pump. The priority flow is adjustable from 0 to 30 GPM (114 LPM). The excess or bypass flow can be used in a second circuit or directed to reservoir.

Max. Flow - 30 GPM (114 LPM)
Max. Pressure - 3000 PSI (207 BAR)
Ports - 3/4" N.P.T.

**RV-30, RV-60
Pilot Operated
Relief Valves**



Maintaining a constant maximum pressure with widely varying flow rates. Can be mounted inline or line mounted.

Model - RV-30
Max. Flow - 30 GPM (114 LPM)
ADJ Pressure Range -
300-3000 PSI (21-207 BAR)
Ports - SAE-10 Straight Thread
[Preset at 1000 PSI (69 BAR)]

Model - RV-60
Max. Flow - 60 GPM (227 LPM)
Range - 300-3000 PSI (21-207 BAR)
Ports - SAE-16 Straight Thread
[Preset at 2000 PSI (138 BAR)]

Call for larger capacity or higher pressure requirements.



MP93-02 (Rev. 7-10) Printed in the U.S.A.
© Muncie Power Products, Inc. 2010

Muncie Power Products, Inc. Member of the Interpump Hydraulics Group
General Offices and Distribution Center • P.O. Box 548 • Muncie, IN 47308-0548
(765) 284-7721 • FAX (765) 284-6991 • E-mail info@munciepower.com
Web site <http://www.munciepower.com>

Drive Products, Exclusive Agents for Canada, ISO Certified by an Accredited Registrar

