

RT 80

Rototilt designed for excavators
with machine weight 23–30 tonnes (50,700–66,100 lb)



TECHNICAL DATA RT 80	METRIC	IMPERIAL
Min/Max machine weight	23-30 tonnes	50,700–66,100 lb
Maximum standard bucket volume	1.6 m ³	2.1 yd ³
Maximum bucket digging force	200 kN	44,960 lb
Weight	from 730 kg*	1,610 lb
Tilting angle	2 x 40°	2 x 40°
Rotation	unlimited	unlimited
Rate of rotation (@50 l/min)	1 turn / 7 seconds	1 turn/7 seconds
Min/Max connection pressure	20/30 MPa**	2900/4350 psi**
Working pressure	25 MPa	3626 psi
Max return pressure (@50 l/min)	2 MPa	290 psi
Min/Max connected flow	50/80 l/min	13.2/21.1 gpm
Number of lubrication points	8	8

* The weight depends on the type of adapter, quick coupler and control system.

** Separate connection for hydraulic motor max 25 MPa (3626 psi).

DIMENSIONS RT 80	MM	INCH
Applies for RT 80 S70/S70		
A	920 mm	36.22 in
B	620 mm	24.41 in
C	940 mm	37.01 in

² With double acting cylinders

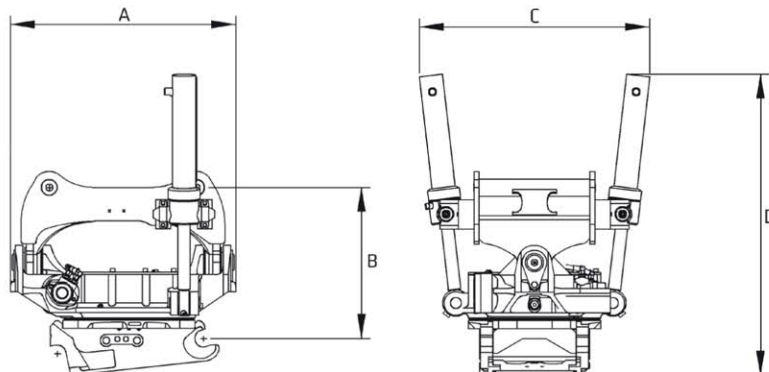

RT 80 S70/S70 with double acting cylinders



RT 80 Multi/S2 with double acting cylinders

The pictures above only show two of several possible configurations for the RT 80.