

# STORM

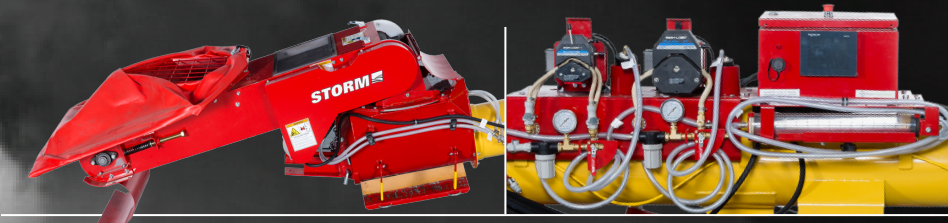

**STORM** Seed Treater

TAKE THE GUESS WORK OUT OF SEED TREATMENT WITH THE  
**STORM SEED TREATER.**



Six access ports allow for easy STORM and auger clean out

Enclosed mixing and spraying provides safe and efficient application

Peristaltic metering pumps precisely meter seed treatment to match seed flow

Electronic controls provide a simple interface with touch screen input and pre-programmed recipes

## SPECIFICATIONS

- Electronic control system: 120 VAC x 15 Amps required
- Pre-programmed for Bayer CropScience seed treatment products with the ability to store ten other treatment products such as liquid inoculants and seed nutrition
- The ability to store 20 pre-programmed jobs which contain seed, treatment product information and calibrations
- The integrated mixing auger has a 10" tube, 41' length and features a self-propelled heavy-duty mover kit for improved mobility in the yard
- A variety of pump head and tubing options means that the STORM can handle a wide range of liquid treating products
- 3/8" ID hose with no drip quick connect couplings
- Two easy access spray nozzles connected to each pump for a total of four nozzles
- The two pump flows can be combined into one pair of nozzles for additive products or the two pump flows can be kept separate for higher rate products
- 32.5hp Kohler motor with electric clutch
- Tested and set auger speed to optimize coverage and reduce impact on seed
- Capable of seed flows of 1800 lbs/min (815 kgs/min) in wheat, peas and lentils, 1440 lbs/min (653 kgs/min) in barley and 1200 lbs/min (544 kgs/min) in oats \*\*
- Cleated belt with low friction technology
- +/- 3% accuracy on metering of seed (with the proper use of the seed density measuring kit)\*\*
- Metric or imperial units
- Seed types: wheat, barley, oats, peas and lentils
- Powder coated steel construction
- First of its kind mover kit with a self-locking transport function - locks without the use of pins or chains, and includes a full-lift lockout for easier maintenance and cleaning

All great crops begin with the seed. Properly protecting that seed is the first investment in a great harvest, which is why we are proud to introduce a new era in seed treating. The STORM (Seed Treatment Optimized Rate Metering) is the latest innovation in seed treatment equipment, delivering precision application in a convenient and simple to use package for in-the-yard treating that you control. Specifically designed to maximize the return of seed applied products and to take the guesswork out of the application process.

## KEY FEATURES

### EASY, IN-THE-YARD, JUST IN TIME TREATING

- The STORM allows seed treatment to be applied where you want it, when you want it, in one simple step
- The STORM is very portable. Move from bin to bin with the robust mover kit or from site to site by towing the one-piece unit down the road

### TREATING WITHOUT THE MESS

- With the STORM, the treating process is completely enclosed reducing exposure and mess from the treatment products and treated seed
- The closed calibration system reduces operator contact and ensures that proper treatment rates are achieved each and every time
- Connect directly to the seed treatment containers to get treated seed back in the truck without handling the product

### GENTLE & FLEXIBLE

- The specially designed integrated mixing auger ensures consistent seed coverage and minimizes damage to seed
- The STORM is suitable for a wide variety of crops including Wheat, Barley, Oats, Peas and Lentils using a wide variety of liquid treatment products

### ACCURACY & CONTROL

- Electronic controls provide a simple, easy to use interface with touch screen inputs and pre-programmed recipes giving you complete control over the treating process
- The electronically controlled metering conveyor and peristaltic pumps deliver unmatched treating accuracy of +/- 3%\*\*
- Seed flow and treatment flow are controlled by the electronics simultaneously, ensuring that proper application rates are achieved every time
- Through constant feedback from the electronics, and with the ability to treat a batch of seed the STORM provides ultimate control over the delivery of seed
- Reversible peristaltic metering pumps make the calibration process quick, easy and efficient



**STORM**

**STORM** | [aggrowth.com/storm](http://aggrowth.com/storm)

# COMPETITIVE FEATURES

FEATURES	STORM	COMPETITORS
<b>Grain Metering</b>	Yes	Limited
– Type	Metering Conveyor	Calibrated Auger
<b>Liquid Metering</b>	Yes	Limited
– Type	Peristaltic	Diaphragm Pump
<b>Treatment Enclosure</b>	Excellent	Poor
<b>Integrated Application &amp; Mixing Device</b>	Yes	No
<b>Electronic Controls</b>	Yes	No
<b>Programmed Recipes</b>	Yes	No
<b>Easy Calibrations</b>	Yes	No
<b>Job Tracking</b>	Yes	No
<b>Mobility &amp; Ease of Set-Up</b>	Yes	No

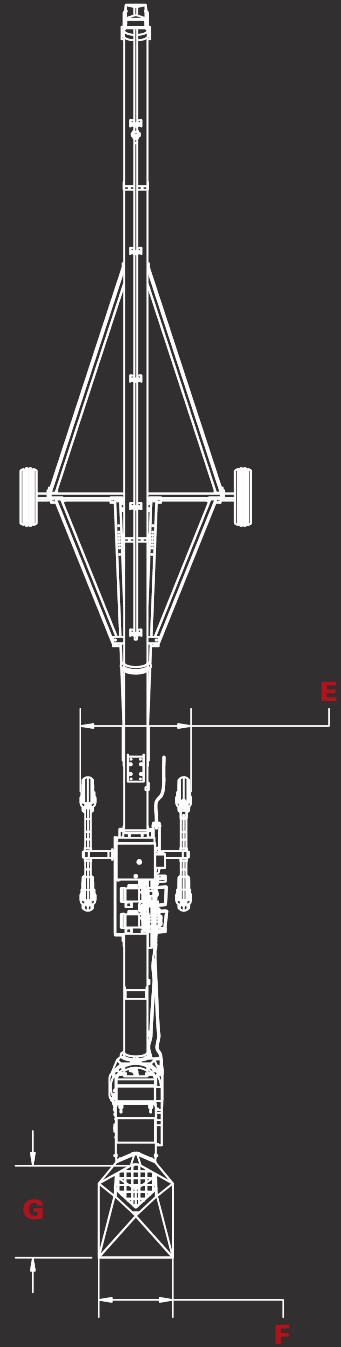

## STORM KEY MEASUREMENTS

Spout Height from Ground (D)	A	B	C	D	E	F	G
14'	22"	8'9"	15'6"	14"	4'	2'8"	3'3.5"
10'	21"	9'1"	15'9"	10'	4'	2'8"	3'3.5"

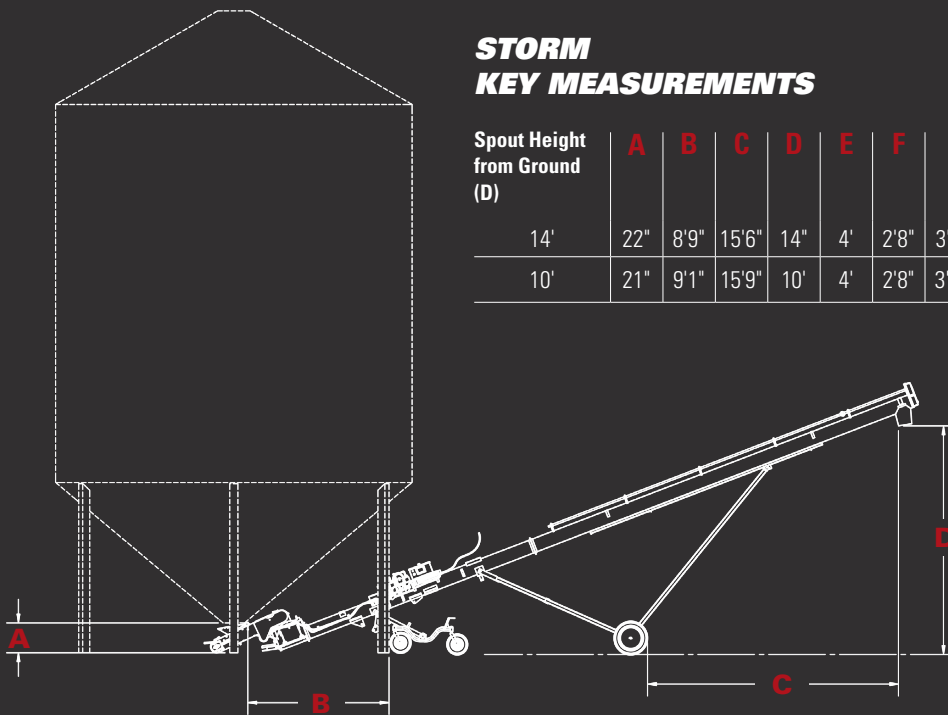

# STORM



Box 39, 74 Main Street  
Rosenort, Manitoba  
Canada R0G 1W0

855.662.6609  
storm@aggrowth.com  
aggrowth.com/storm

**AGI**  
AG GROWTH INTERNATIONAL