

instruction manual

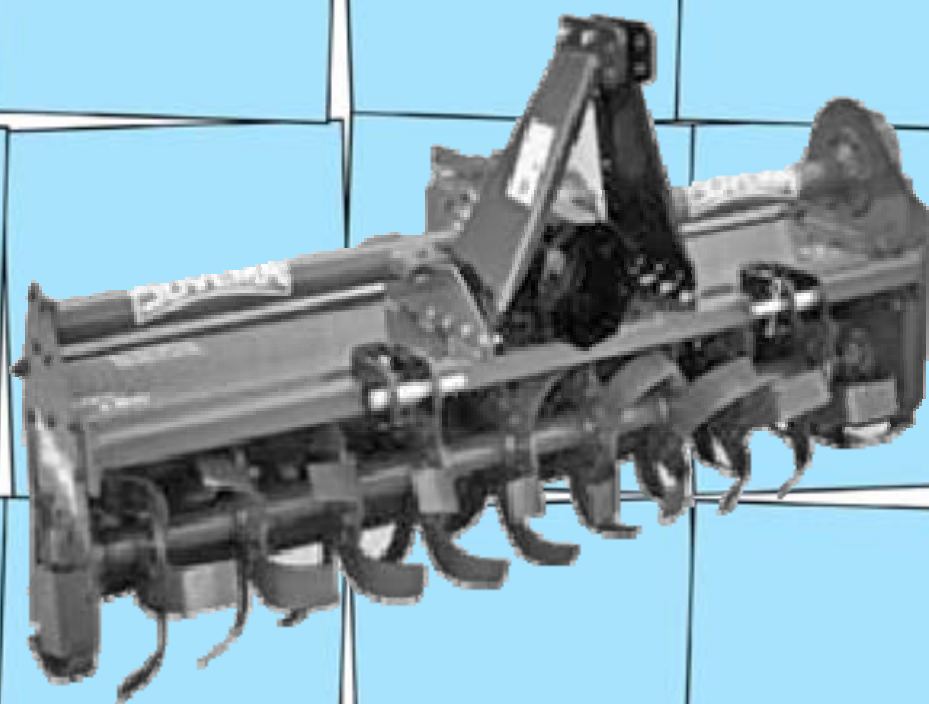

ROTARY TILLER

GP / C



Dear Owner,

Thank you for buying a SOVEMA manufactured product.

Your new machine is carefully designed and manufactured to give you superior performance and dependable service, if properly operated and maintained.

You will find this machine to be rugged and reliable when matched to the suggested horsepower operating range.

Much time has been invested in providing safety and protection. Please carefully read this manual. It tells you how to safely and easily assemble, operate and maintain your machine.

Be sure that you and any other operator carefully follow the recommended safety practices at all times. Failure to do so could result in personal injury or property damage.

Of course, if you should ever have any problems or questions, please contact your local SOVEMA dealer or contact us at the addresses or numbers indicated in this manual.

SOVEMA manufactures a variety of innovative equipment. If you are interested in reviewing our full line, please contact us.

Thanks for your choice.

Ginettino Mayer  
President

# TABLE OF CONTENTS

- SYMBOLS	Page 3
- GENERAL INFORMATION	Page 4
- SAFETY AND WARNING DECALS	Page 5
- SAFETY INSTRUCTIONS	Page 7
- MAIN CHECK	Page 10
- TECHNICAL SPECIFICATIONS	Page 11
- ATTACHING THE MACHINE TO THE TRACTOR	Page 12
- DEPTH CONTROL	Page 16
- BEGINNING WORK	Page 19
- TROUBLE SHOOTING	Page 20
- DISCONNECTING THE MACHINE FROM THE TRACTOR	Page 22
- STORING OF THE MACHINE	Page 23
- MAINTENANCE	Page 24
- PARTS LIST	Page 29
- WARRANTY POLICY	Page 38
- SOVEMA PRODUCT LINE	Page 42

# SYMBOLS

These symbols appear throughout the manual.  
Remember their meaning and advice.



**CAUTION!**  
**YOUR SAFETY IS INVOLVED**



**READ CAREFULLY**



**USE PROTECTIVE GLOVES**

# GENERAL INFORMATION



All implements with moving parts are potentially hazardous. The manufacturer has designed the implement to be used with all the safety equipment properly attached. The purpose of this manual is to assist you in safely maintaining and operating the implement.

These instructions have been compiled from our experience. Through this experience and these instructions, you should be able to develop operating procedures suitable to your particular situation.

Illustrations and data used in this manual may vary slightly in some details. Throughout this manual references are made in left and right directions. These are determined by standing at the rear of the equipment and facing the direction of forward travel.

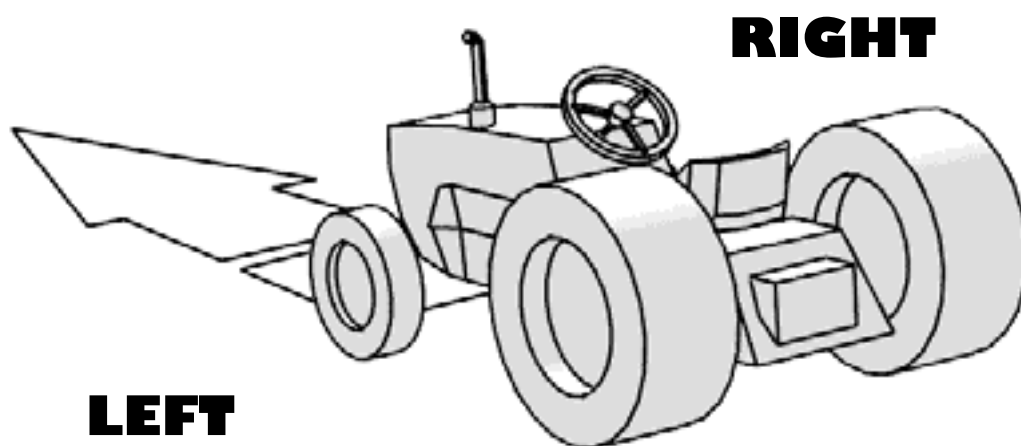

Even if some illustrations in this manual show the machine with safety shields removed for a better view, never operate in these conditions.

**BEFORE OPERATING THE IMPLEMENT, ALL SAFETY SHIELDS OR DEVICES MUST BE MOUNTED.**

# SAFETY AND WARNING DECALS



Safety decals on the implement contain important safety warning messages. To prevent injuries we invite the operator to read them carefully and keep them clear. Check that all the decals are on the machine. If not, **DO NOT USE** the machine and report to the Dealer immediately to get the decals. Decals on the machine are the following and mean:

:



1

2

3

4



1. Before operating the equipment, read carefully the operator's manual.



2. Before maintenance operation, lower the implement, shut off the engine and read the Operator's manual.



3. Do not allow riders on tractor or implement.



4. Do not stand behind the tractor during the operations..



5. Before operating the equipment, read carefully the Operator's manual.



6. DANGER! Entanglement of driveline..



7. KEEP AWAY from driveline in operation: contact can cause death!



8

 8. Danger. Your hands and feet can be injured by moving parts. Keep away from the implement.



9

 9. Danger. Your feet can be injured. Keep away from the implement.

10

 10. Danger. Your hands can be injured. Do not remove safety protection and keep away from moving parts.





11

 11. Danger. Your hands can be injured. Do not remove the cover and keep away from moving parts.

**540 rpm**

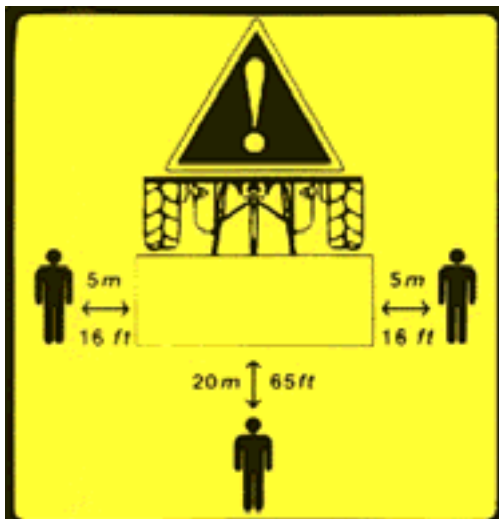
 12. The machine is designed for use on tractors with 540 RPM PTO only.



 13. Caution! During working operations all bystanders must stay beyond the shown distances from the implement.











# SAFETY INSTRUCTIONS



Before using the implement you must be sure to know the main safety precautions; in fact many accidents are caused by not observing these rules.





## Pre-operational and operational safety rules

-  Make sure that no person operates this machine unless they first thoroughly read and study the operator instructions for this machine and understand all the safety precautions.
-  Keep all guards, shields and safety decals in place and proper working order before operating this machine.
-  Operate only with a tractor equipped with an approved Roll Over Protective System (ROPS) and always wear your seat-belt.
-  Operate only in daylight or good artificial light.
-  Only trained personnel can operate with the tractor and the implement.
  
-  Personal protection equipment, including safety shoes, safety glasses, hard hat and gloves are recommended during the different operations. Do not allow long hair, loose fitting clothing or jewellery to be around moving parts.
  
-  **Do not leave the tractor seat until the engine is completely turned off, brakes locked and ignition key removed.**
  
-  Do not allow riders on the machine or tractor at any time. No safe place for any rider.
-  Before starting to operate, be sure that the tractor's PTO is set to match the PTO requirements of the implement. The speed is indicated in this manual and on the implement.
-  Do not use different driveline . Always use type and size supplied by the manufacturer.
-  Make sure driveline spring-activated locking pin operate freely and are seated firmly in tractor PTO stub shaft groove.





 For engaging or disengaging the tractor PTO, refer to your tractor manual .

 Connect and disconnect PTO shaft only when tractor engine is turned off.

 Keep hands, feet, hair and clothing away from moving parts.

 To prevent injury by thrown objects DO NOT operate unless all personnel, livestock and pets are 20 m (65 ft) away.

 The rotating parts of the machine have been designed and tested for rugged use. However they could fail upon impact with heavy solid objects. Such impact could cause the broken objects to be thrown outward at very high speed. To reduce the possibility of serious injury, or even death, never allow the rotating parts to contact such obstacles.

 Stop the machine and tractor immediately upon striking an obstruction. Turn engine off, remove key, inspect and repair any damage before resuming operation.

 No repairs or adjustments should be attempted while the machine is attached to a tractor that is turned on.

 Working inclination of PTO driveline must not exceed 25° (see fig.1). Greater working angles will damage the PTO and serious personal injury could occur as well.

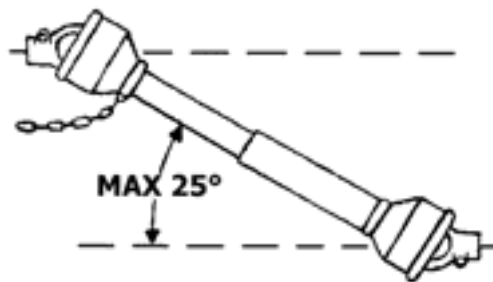

 Disengage tractor PTO and place transmission into neutral before attempting to start engine.

## **Transport safety**

 Plan your route to avoid heavy traffic.

 For public roads, comply with state and local safety and movement rules.

 Be sure that the implement is in the raised position for transport.



When you drive, do not drink alcohol.



Pay attention to traffic when operating near or crossing roadways.



Reduce speed when transporting mounted implement to avoid bouncing and loss of steering control.



Pay attention when you turn curves or you go up and down on hills with the implement. Be sure that at least 25% of the tractor's weight is on the front wheels to maintain safe steering. Drive at a low speed.



NEVER allow riders on implement or tractor. Falling off can kill.



Drive .

## Maintenance safety



Good maintenance is your responsibility. Poor maintenance is an invitation to trouble.

### **For maintenance follow these common practises:**



- keep service. area clean;
- use adequate illumination for the job;
- be sure tools and electrical outlets are properly grounded;
- make sure there is plenty of ventilation.



Before making maintenance on this machine, drive to a level area, disengage the PTO, lower the machine, turn off the engine, set the brakes and remove the ignition key.



Keep all persons away from operator control area while performing maintenance.



**ALWAYS** use personal protection devices.



Periodically tighten all bolts, nuts and screws.



The implement manufacturers assumes no liability if replacement parts other than the original factory parts are used.



After servicing, be sure that all safety shields are re-installed properly.



Be sure that all safety decals are installed, clean and in good condition.



If the machine is modified from the original design, no responsibility for the manufacturer can be claimed.

# MAIN CHECK LIST



Before connecting the machine to the tractor, read the following instructions:

- Make sure that the weight and power of the tractor is correct with the machine you want to connect. If you have any doubt, see the technical specifications.



- Ensure that all safety decals are properly installed and clean.
- Check oil in the gearbox. With low oil, gears get damaged.
- Make sure that all safety shielding are properly installed and in good condition.

# TECHNICAL SPECIFICATIONS



The machine described in this manual is a **GP / GPC** series tiller.

## GP

MOD.	Working Width		Working positions		HP	PTO (rpm)	Rotor (rpm)	Weight		Blades 4 - 6
	cm	inches	Sx cm/inches	Dx cm/inches				Kg.	Lbs	
<b>GP 140</b>	140	56"	65/26"	75/30"	30 - 45	540	230	287	633	28 - 42
<b>GP 160</b>	160	64"	75/30"	85/34"	35 - 50	540	230	304	671	32 - 48
<b>GP 180</b>	180	72"	85/34"	95/38"	35 - 55	540	230	340	750	36 - 54
<b>GP 200</b>	200	78"	100/39"	100/39"	40 - 60	540	230	372	820	40 - 60

## GPC

MOD.	Working Width		Working Positions		HP	PTO (rpm)	Rotor (rap.) (rpm)	Weight		Blades 4 - 6
	cm	inches	Sx cm/inches	Dx cm/inches				Kg.	Lbs	
<b>GPC 140</b>	140	56"	65/26"	75/30"	30 - 45	540	17-21 177 18-20 197 20-18 243 21-17 270	295	650	28 - 42
<b>GPC 160</b>	160	64"	75/30"	85/34"	35 - 50	540		312	686	32 - 48
<b>GPC 180</b>	180	72"	85/34"	95/38"	35 - 55	540		348	766	36 - 54
<b>GPC 200</b>	200	78"	100/39"	100/39"	40 - 60	540		380	836	40 - 60

The GPC version comes with a couple of gears that grants the rotor 197 rpm.

## LE VEL OF NOISE RESULT WHEN IDLING

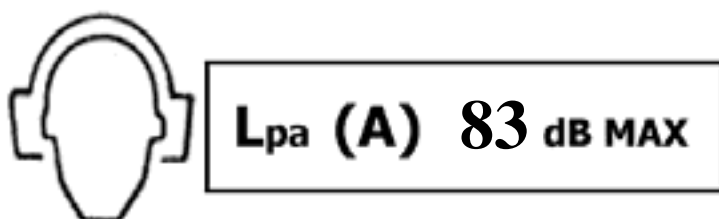

# ATTACHING THE MACHINE TO THE TRACTOR



The machines described in this manual do apply to any kind of tractor provided of universal third hitch point.

The characteristics (length, diameter of the holes for the lifting pins) of the tractor's lifting arms depend on the type of tractor utilized, therefore it is necessary to prepare the machine in order to conclude the attachment correctly.

Before attaching the machine to the tractor you must be sure that the engine is turned off, brakes are locked and the ignition key is removed.

This operation must be made on a flat area as it is very dangerous.



Do not allow anyone between tractor and the machine when the engine is running.

Follow these instructions:



Connect the hitch of the drawbar to the tractor using a hitch pin and the hair clip pin (see fig. 1).

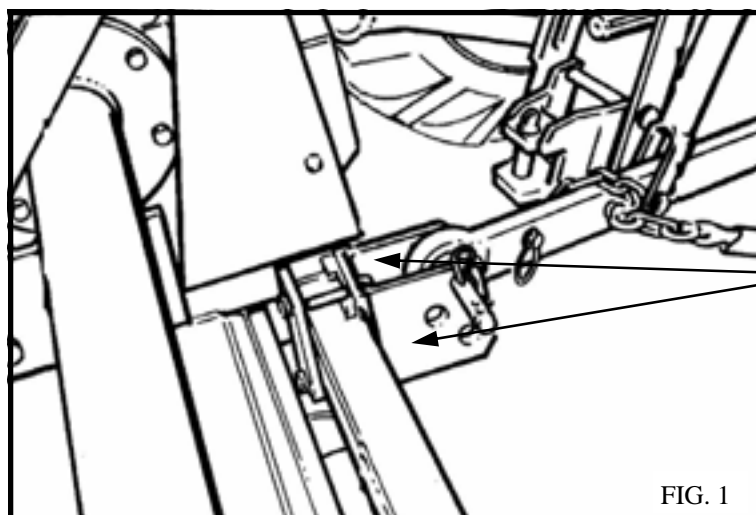

Lower Plates

FIG. 1



Connect the third point of the tractor to the upper plates of the machine using a hitch pin and the hair clip pin (see fig. 2). By means of the tie rod of the hitch point, which permits regulation of the machine's inclination, set the machine even to ground-floor (see fig. 3). This procedure extends the life time of the PTO shaft and the machine.

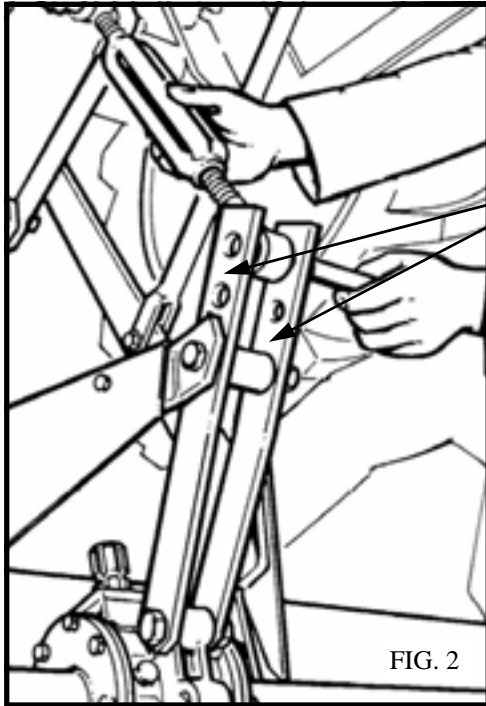

UPPER TIE  
RODS

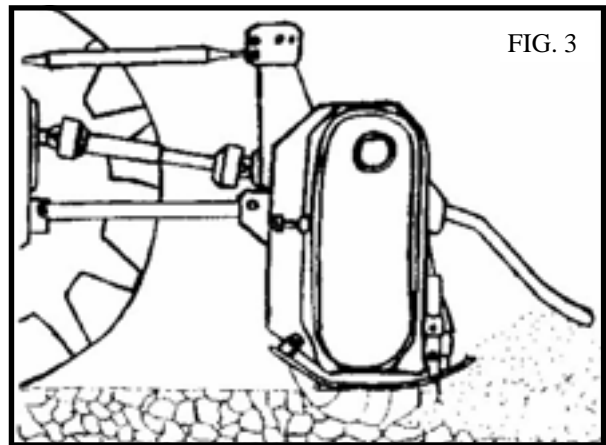

FIG. 3



Connect the PTO shaft and be sure it is correctly connected to the tractor and machine.

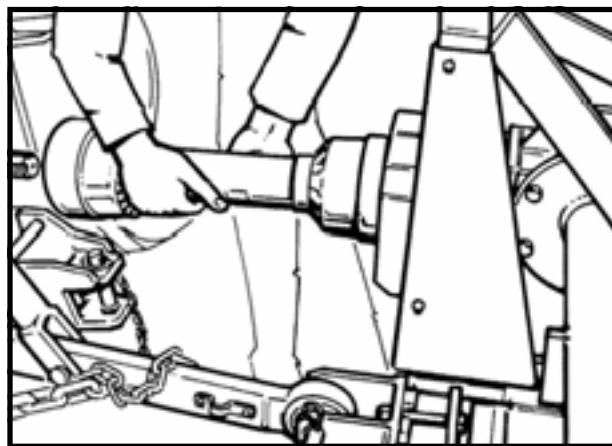

FIG. 4

## Shortening of the PTO shaft

Due to the many different types of tractors, it may be necessary to shorten the PTO shaft.



Always refer to the manual of the driveline's manufactures. Read it carefully.



In case shortening is needed, listed below are some basic guidelines on performing this modification. Determine how much length is to be removed, then:

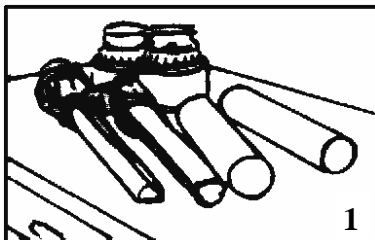

1) Remove plastic protection (both sections)

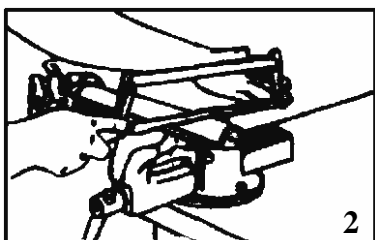

2) Cut the excess length of both tubes

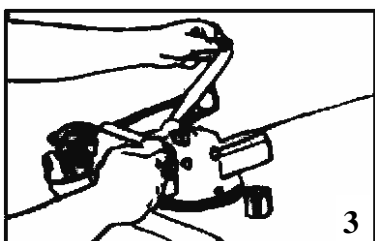

3) Deburr and clean the saw-dust off ends of tubes. Remove packing inside shaft tubing

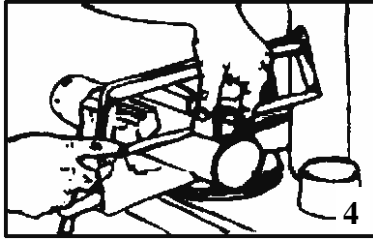

 4) Cut the plastic protection to the same length you have cut the joints

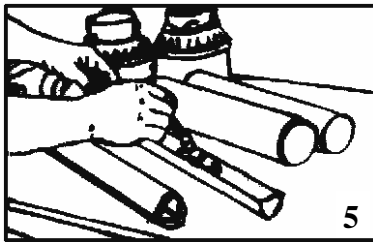

 5) Grease the male joint section and reassemble protection



Do not use PTO shafts without proper shielding installed.



# DEPTH CONTROL



To set the machine's working depth, adjust the two lateral skids as in figure 1:

- Loosen screw "a".
- Unscrew screw "b".
- Adjust the skid as wished screwing down screw "b" in one of the holes located in the same skid.
- Adjust screw "a".

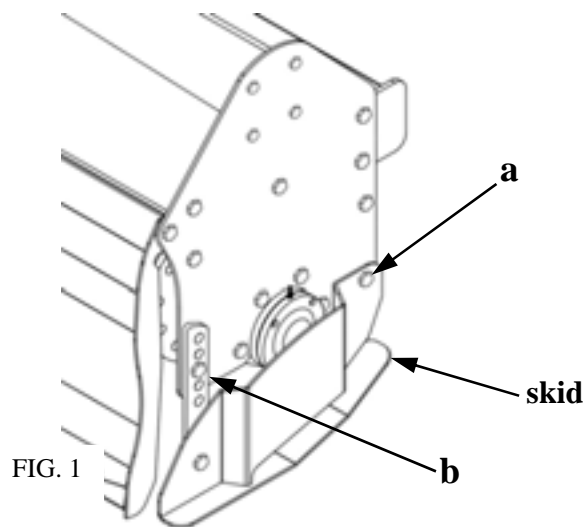

In order to get an even soil, make sure that both skids are at the same position.



If your machine is equipped with a rear roller, the depth adjustment is made by a crank (fig. 2).

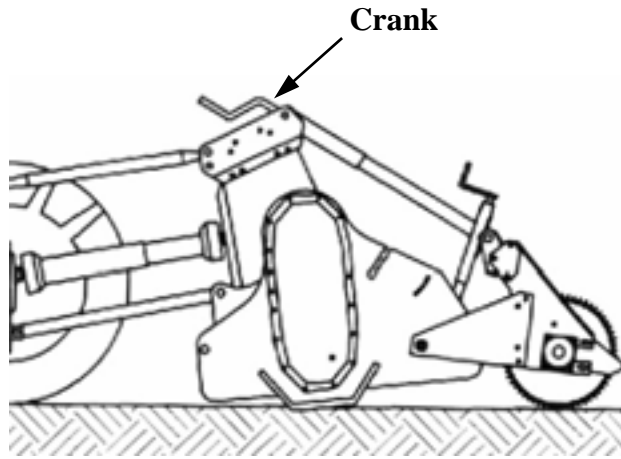

FIG. 2



## GEAR SPEED— GPC Series

These machines are equipped with a 4 speed gearbox, which permits to change the rotor speed.



Higher rotor speed allows better tilling of the soil.



To change speed follow these steps:

- Pay attention: oil can come out, so position the machine in a way that the rear part is higher than the front.
- Unscrew the bolts and remove the rear cover of the gearbox.
- According to the required speed, change position of the gears (See chart in chapter on Technical Specifications).
- Mount back the rear cover and screw in the bolts.



**Be very careful and ensure to use the right gears, since some gear pairs cannot be inverted, and gears from different pairs cannot be interchanged. Use only original gears!**

# BEGINNING WORK



After completing all safety controls and having made sure that the machine is parallel to the ground, proceed as follows:

- Raise the machine off the ground in order to let the blades start moving without touching ground and avoid damage.
- Maintaining the machine lifted, engage the tractor PTO at suggested engine RPM.
- Start moving the tractor forward and then gradually lower the machine.

## TIPS TO GET DESIRED RESULTS



Proper ground speed of the machine depends on the type of terrain to work. However it is advisable not to exceed 5 Km/h.

For a very fine seedbed, lower the rear shield completely and operate at a very slow speed. For a more coarse seedbed, raise the shield and/or increase operating speed, not exceeding the speed suggested before.



While operating, to avoid damage do not attempt to make turns and DO NOT go backwards. Disengage the machine and raise it off the ground when making turns and U turns.

# TROUBLE SHOOTING



During work several problems may arise:

## Unusual noise

While working, if the machine makes unusual noises, the operator must stop it immediately and follow these instructions:

- **Check for broken/bent parts.**
- **Check for a sudden movement of the lateral cover after a casual impact.**

A sudden impact with an obstacle can move the cover out of place causing the oil to leak. This can make the gears not correctly lubricated, noisy, and in danger of breaking.

- **Check for correct oil level in the gearbox.**

If there isn't the correct, minimum quantity of oil in the gearbox (see chapter on maintenance), the gears will not be lubricated correctly. If corrective measures are not taken immediately and the machine is left to work, the oil temperature will increase rapidly. This in turn will determine the breaking of the gears and their bearings.

- **Check condition of rotor support bearings.**

Inadequate lubrication (see chapter on maintenance) may cause damage on one of the two rotor support bearings. The rotor begins to oscillate causing excessive vibration to the frame And will quickly produce damages to the weldings.

Another possible cause for damages is the improper use of the machine: high ground speed, turns/U turns, going backwards, or operating in soil with high rock content.

## **Inconsistent results**

While operating, if you notice that work is not uniform, stop the machine and check that no object has been trapped in the rotor.









Before checking the machine to find the possible cause of the problem, be sure the tractor's PTO is disconnected, the engine is turned off, brakes are on, ignition key off the command board and the machine is completely lowered to the ground.

# DISCONNECTING THE MACHINE FROM THE TRACTOR



Disconnection of the machine must be carried out on flat area, and it is considered a very dangerous operation. You must pay attention. Follow these instructions:



-  While remaining in the tractor seat, put the tractor's PTO in neutral.
-  When the rotor has completely stopped, turn off the engine and set the parking brakes.
-  Lower the tiller until the skids are touching the ground. Remove ignition key.
-  Disconnect the driveline and disengage the machine from the tractor.
-  If you have an hydraulic folding machine, disconnect the hydraulic hoses from the tractor.
-  Engage the parking stand and disconnect the hitch of the drawbar from the tractor.



Before disconnecting the driveline, be sure the tractor PTO is in neutral and engine is off.

# STORING OF THE MACHINE



Since your machine is an investment, we suggest the following procedures if it remains unused for a long period of time:

- Wash and dry the machine.
- Check all moving parts; in case of excessive wear replace the parts or contact your local dealer.
- Check bolts and nuts for proper tightness.
- Lubricate all the active parts like bearings, all grease zerk locations and other pivot or worn points that may not have a fitting.
- Lubricate all non-painted parts.
- Store the machine in a clean and dry place under roof.



# MAINTENANCE



To ensure a long life to your machine and a trouble free operation, regular maintenance program is required.

The recommended phases of maintenance are for normal use and can be varied depending on different usage conditions.



Always disengage tractor PTO before starting maintenance.



## Every 10 working hours

- Check for loose bolts that fix the blades to the rotor. Tighten as needed (see fig. 1).
- Grease the PTO shaft components.
- Clean the end of PTO shaft with non toxic / non inflammable detergent.
- Make sure that driveline shields are in place and in good condition.
- Grease the right lateral support of the rotor (see fig. 2) after cleaning correctly the grease nipples for better lubrication. Use lithium type grease NLGI 2
- Clean the machine.

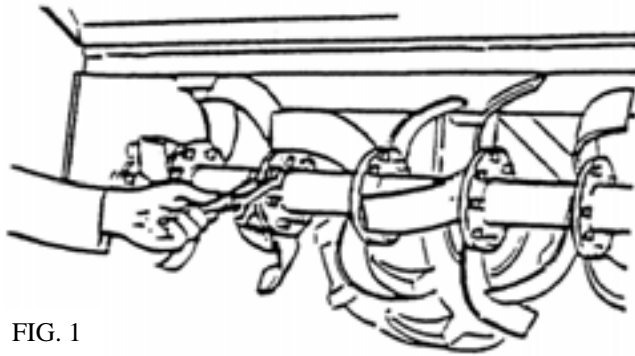

FIG. 1

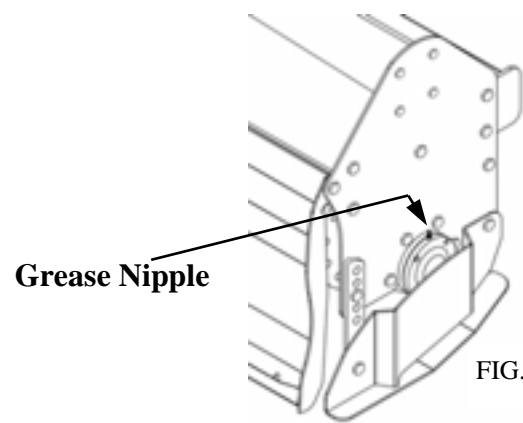

FIG. 2

### Every 50 working hours

- Check blades for wear. Replace if necessary. Use only original parts.
- Make sure PTO shaft and slip clutch are in place and in good condition. If damaged or worn, replace slip discs. Contact your local dealer for substitution.
- For those machines supplied with rear roller, grease the screw and lateral supports, after cleaning correctly the grease nipples for better lubrication. Use lithium type grease NLGI 2.
- Check oil level in the gearbox.

On the GP series, this operation is carried out by unscrewing the oil level plug located in the back of the gearbox (1 in fig. 3). If you need to add oil, unscrew the filler plug (2 in fig. 3) and fill in the box until it starts running out of the level hole.

For the RPC2 version, this operation is carried out by unscrewing the oil level plug positioned on top of the gearbox (3 in fig. 3) and checking the oil measurer supplied with the plug. This measurer indicates MIN / MAX oil level.

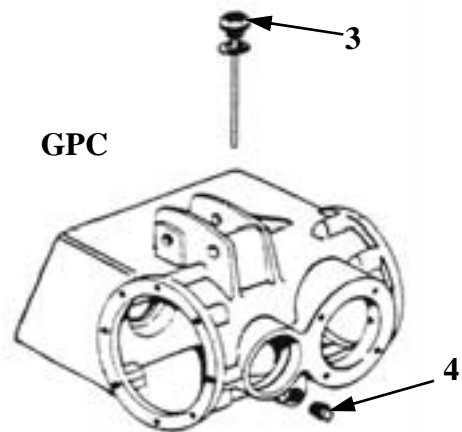
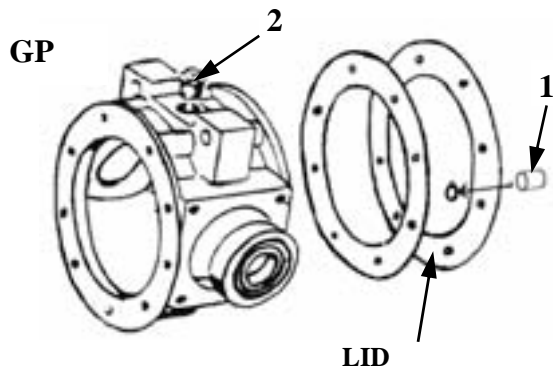

FIG. 3

- Check oil level in the gear cover by unscrewing the oil level plug (5 in fig. 4). If you need to add oil, unscrew the filler plug (6 in fig. 4) and fill in the cover until it starts running out of the level hole.

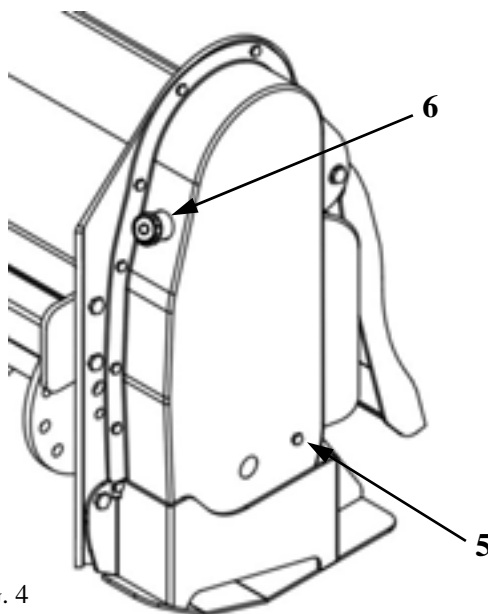

FIG. 4

### **First 100 working hours**

In case the machine has done its first 100 hours, change oil in the gearbox and gear drive.

For the GP series, to change the oil in the gearbox, unscrew the oil level plug and drain all the oil through it, after inclining the machine.

For the GPC version, to change oil in the gearbox, unscrew the discharging plug (4 in fig. 3) and drain all the oil through it, after inclining the machine.

For both versions, to change oil in the cover, drain all the oil from the oil level hole, located in the lower part of the cover (after inclining the machine). This change is necessary because the gears are new and so are subject to quicker worn.

Use oil: SAE 80W 90 API GL 4.

**Every 300 working hours**

- Completely replace oil in the gearbox and gear drive, as explained before.  
Use oil: SAE 80 W 90 API GL 4.

# TOXICOLOGICAL INFORMATION ABOUT LUBRICANTS



	<b>DANGER</b>	<b>PROTECTIVE MEASURES</b>	<b>PRIMARY INTERVENTION</b>
<b>SKIN</b>	Possibile irritation after prolonged contact	Glover and/or lotion barrier	Clean with running water and soap
<b>EYES</b>	Possibile irritation on contact	Protective glasses	Wash with running water
<b>INHALATION</b>	Possibile irritation after prolonged contact	Maintain an oil mist level of 5 mg / m <sup>3</sup> between TLV-TWA limits	Espose to fresh air and call for medical assistance immediately
<b>INGESTION</b>	Such possibilità is not taken into account		DO NOT provoke vomiting, call for immediate medical assistance.



**EXCLUSIVELY USE ORIGINAL  
SPARE PARTS FROM  
SOVEMA**

# SPARE PARTS LIST

## Mod. **GP/C**

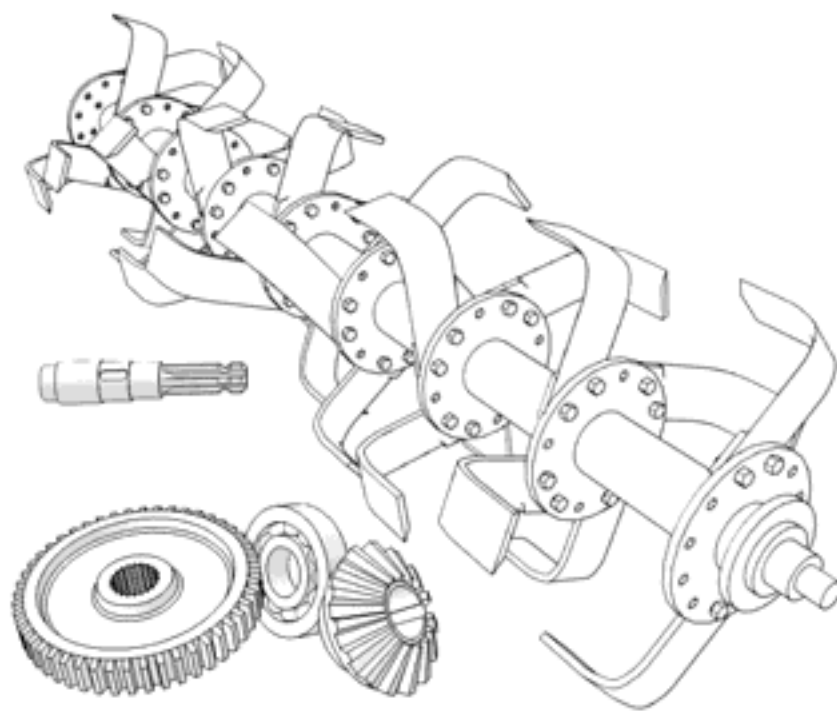

# GP GPC

## FRAME

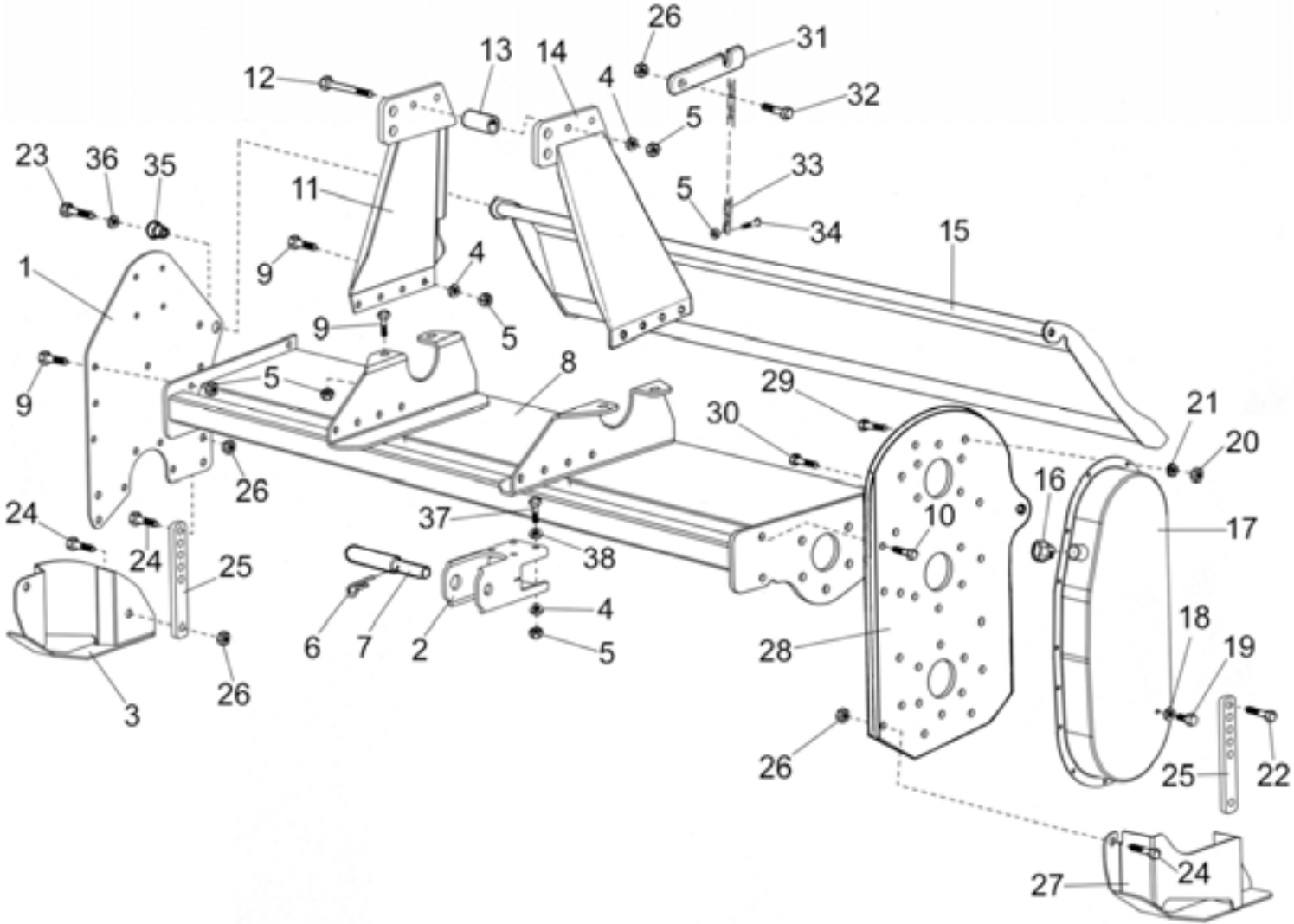

REF	CODE	QTY	ENGLISH	FRANÇAIS	ITALIANO	DEUTSCH	ESPAÑOL	NOTE
1	900142059.0	1	SIDE	FLANC	FIANCO	SEITE	FLANCO	
2	900116084.1	2	HITCH	ATTELAGE	ATTACCO	ANBAU	ENGANCHE	
3	900115010.1	1	SKID	PATIN	SLITTA	KUFE	CORREDERA	
4	900.104.036	18	WASHER	RONDELLE	RONDELLA	ZWISCHENSCHLEIBE	ARANDELA	
5	900.103.050	32	NUT	ECROU	DADO	MUTTER	TUERCA	
6	900.108.006	2	SPLIT PIN	GOUPILLE	COPIGLIA	ARRETIERUNG	PASADOR	
7	900.116.033	2	PIN	TOURILLON	PERNO	STIFT	PERNO	
8	900.142.245	1	FRAME	CHASSIS	TELAIO	RAHMEN	BASTIDOR	140
8	900.142.246	1	FRAME	CHASSIS	TELAIO	RAHMEN	BASTIDOR	160
8	900.142.247	1	FRAME	CHASSIS	TELAIO	RAHMEN	BASTIDOR	180
8	900.142.248	1	FRAME	CHASSIS	TELAIO	RAHMEN	BASTIDOR	200
9	900.102.019	17	SCREW	VIS	VITE	SCHRAUBE	TORNILLO	
10	900.102.020	4	SCREW	VIS	VITE	SCHRAUBE	TORNILLO	
11	900.116.077	1	SIDE	FLANC	FIANCO	SEITE	FLANCO	
12	900.102.022	2	SCREW	VIS	VITE	SCHRAUBE	TORNILLO	
13	900.116.027	2	SPACER	ENTRETOISE	DISTANZIALE	ABSTANDSRING	DISTANCIADOR	
14	900.116.078	1	SIDE	FLANC	FIANCO	SEITE	FLANCO	
15	900114005.0	1	SHIELD	CAPOT	COFANO	HAUBE	CARCASA	140
15	900114006.0	1	SHIELD	CAPOT	COFANO	HAUBE	CARCASA	160
15	900114010.0	1	SHIELD	CAPOT	COFANO	HAUBE	CARCASA	180
15	900114011.0	1	SHIELD	CAPOT	COFANO	HAUBE	CARCASA	200
16	900.102.049	1	PLUG	BOUCHON	TAPPO	DECKEL	TAPON	
17	900.113.027	1	COVER	CARTER	CARTER	GEHAEUSE	CARTER	
18	900.104.009	1	WASHER	RONDELLE	RONDELLA	ZWISCHENSCHLEIBE	ARANDELA	
19	900.102.009	1	SCREW	VIS	VITE	SCHRAUBE	TORNILLO	
20	900.103.001	15	NUT	ECROU	DADO	MUTTER	TUERCA	
21	900.104.002	15	WASHER	RONDELLE	RONDELLA	ZWISCHENSCHLEIBE	ARANDELA	
22	900.102.027	1	SCREW	VIS	VITE	SCHRAUBE	TORNILLO	
23	900.102.028	2	SCREW	VIS	VITE	SCHRAUBE	TORNILLO	
24	900.102.026	5	SCREW	VIS	VITE	SCHRAUBE	TORNILLO	
25	900115011.1	2	ROD	TIGE	ASTA	STANGE	VARILLA	
26	900.103.005	7	SCREW	VIS	VITE	SCHRAUBE	TORNILLO	
27	900115009.1	1	SKID	PATIN	SLITTA	KUFE	CORREDERA	
28	900.142.005	1	PLATE	PLAQUE	PIASTRA	PLATTE	PLACA	
29	900.102.008	14	SCREW	VIS	VITE	SCHRAUBE	TORNILLO	
30	900.102.076	1	SCREW	VIS	VITE	SCHRAUBE	TORNILLO	
31	900.142.110	1	HITCH	ATTELAGE	ATTACCO	ANBAU	ENGANCHE	
32	900.102.031	1	SCREW	VIS	VITE	SCHRAUBE	TORNILLO	
33	900.114.015	1	CHAIN	CHAINE	CATENA	KETTE	CADENA	
34	900.102.217	1	SCREW	VIS	VITE	SCHRAUBE	TORNILLO	
35	900.114.032	2	BUSH	COQUILLE	BOCCOLA	BUCHSE	CASQUILLO	
36	900.104.019	2	WASHER	RONDELLE	RONDELLA	ZWISCHENSCHLEIBE	ARANDELA	
37	900.102.023	8	SCREW	VIS	VITE	SCHRAUBE	TORNILLO	
38	900.104.046	8	WASHER	RONDELLE	RONDELLA	ZWISCHENSCHLEIBE	ARANDELA	



# GP

## GEARBOX

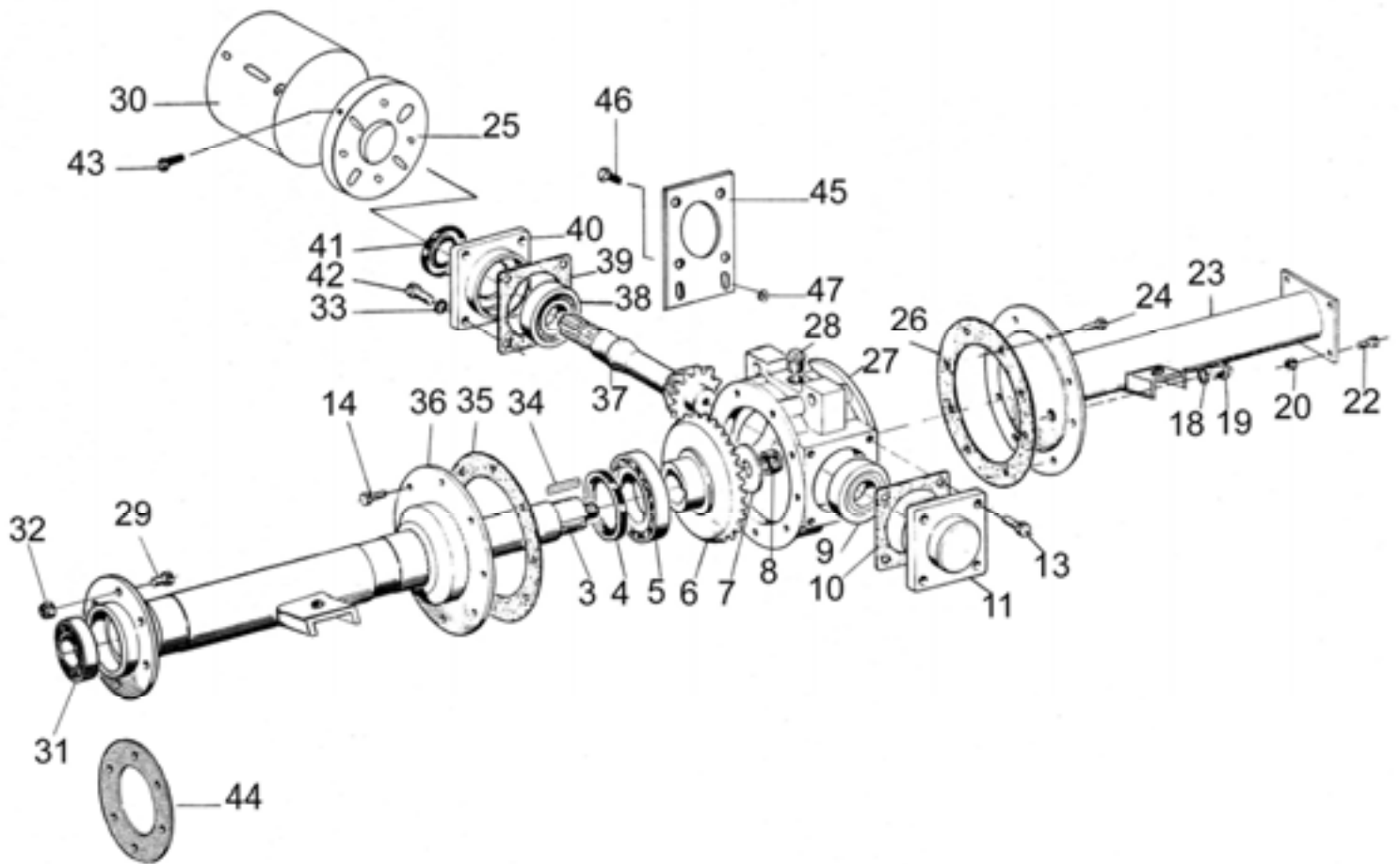

REF	CODE	QTY	ENGLISH	FRANÇAIS	ITALIANO	DEUTSCH	ESPAÑOL	NOTE
3	900.118.047	1	SHAFT	ARBRE	ALBERO	WELLE	EJE	140
3	900.118.048	1	SHAFT	ARBRE	ALBERO	WELLE	EJE	160
3	900.118.049	1	SHAFT	ARBRE	ALBERO	WELLE	EJE	180
3	900.118.050	1	SHAFT	ARBRE	ALBERO	WELLE	EJE	200
4	900.101.005	1	OIL SEAL	PARE-HUILE	PARAOLIO	SIMMERRING	PARA-ACEITE	
5	900.100.010	1	BEARING	ROULEMENT	CUSCINETTO	KUGELLAGER	COJINETE	
6	900.125.005	1	CROWN	COURONNE	CORONA	TELLERRAD	CORONA	
7	900.104.012	1	WASHER	RONDELLE	RONDELLA	ZWISCHENSCHLEIBE	ARANDELA	
8	900.103.014	1	RING NUT	EMBOUT	GHIERA	NUTMUTTER	CASQUILLO	
9	900.100.025	1	BEARING	ROULEMENT	CUSCINETTO	KUGELLAGER	COJINETE	
10	900.139.001	1	GASKET	JOINT	GUARNIZIONE	DICHTUNG	JUNTA	
11	900.125.003	1	CLAMPING	CHAPEAU	CAPPELOTTO	KAPPE	CAPUCHON	
13	900.102.018	4	SCREW	VIS	VITE	SCHRAUBE	TORNILLO	
14	900.102.011	8	SCREW	VIS	VITE	SCHRAUBE	TORNILLO	
18	900.104.009	1	WASHER	RONDELLE	RONDELLA	ZWISCHENSCHLEIBE	ARANDELA	
19	900.102.009	1	SCREW	VIS	VITE	SCHRAUBE	TORNILLO	
20	900.103.002	4	NUT	ECROU	DADO	MUTTER	TUERCA	
22	900.102.011	4	SCREW	VIS	VITE	SCHRAUBE	TORNILLO	
23	900.123.047	1	DOUBLE TUBE	DOUBLE TUBE	DOPPIO CANNOTTO	DOPPELROHR	DOBLE TUBO	140
23	900.123.048	1	DOUBLE TUBE	DOUBLE TUBE	DOPPIO CANNOTTO	DOPPELROHR	DOBLE TUBO	160
23	900.123.049	1	DOUBLE TUBE	DOUBLE TUBE	DOPPIO CANNOTTO	DOPPELROHR	DOBLE TUBO	180
23	900.123.050	1	DOUBLE TUBE	DOUBLE TUBE	DOPPIO CANNOTTO	DOPPELROHR	DOBLE TUBO	200
24	900.102.011	8	SCREW	VIS	VITE	SCHRAUBE	TORNILLO	
25	900.117.070	1	PROT. HOLDER	DISQUE	FONDELLO	ZWSCHUTZHALTER	DISCO	
26	900.139.002	1	GASKET	JOINT	GUARNIZIONE	DICHTUNG	JUNTA	
27	900.125.001	1	CASE	BOITE	SCATOLA	KISTE	CAJA	
28	900.102.051	1	PLUG	BOUCHON	TAPPO	DECKEL	TAPON	
29	900.102.020	6	SCREW	VIS	VITE	SCHRAUBE	TORNILLO	
30	900117072.2	1	GUARD	PROTECTION	PROTEZIONE	SCHUTZ	PROTECCION	
31	900.100.016	1	BEARING	ROULEMENT	CUSCINETTO	KUGELLAGER	COJINETE	
32	900.103.050	6	NUT	ECROU	DADO	MUTTER	TUERCA	
33	900.104.010	2	WASHER	RONDELLE	RONDELLA	ZWISCHENSCHLEIBE	ARANDELA	
34	900.105.001	2	KEY	CLAVETTE	CHIAVETTA	KEIL	CHAVETA	
35	900.139.002	1	GASKET	JOINT	GUARNIZIONE	DICHTUNG	JUNTA	
36	900.119.036	1	TUBE	TUBE	CANNOTTO	ROHR	TUBO	140
36	900.119.037	1	TUBE	TUBE	CANNOTTO	ROHR	TUBO	160
36	900.119.038	1	TUBE	TUBE	CANNOTTO	ROHR	TUBO	180
36	900.119.039	1	TUBE	TUBE	CANNOTTO	ROHR	TUBO	200
37	900.125.004	1	PINION	PIGNON	PIGNONE	RITZEL	PINON	
38	900.100.020	1	BEARING	ROULEMENT	CUSCINETTO	KUGELLAGER	COJINETE	
39	900.139.001	1	GASKET	JOINT	GUARNIZIONE	DICHTUNG	JUNTA	
40	900.125.002	1	CLAMPING	CHAPEAU	CAPPELOTTO	KAPPE	CAPUCHON	
41	900.101.006	1	OIL SEAL	PARE-HUILE	PARAOLIO	SIMMERRING	PARA-ACEITE	
42	900.102.018	4	SCREW	VIS	VITE	SCHRAUBE	TORNILLO	
43	900.102.256	3	SCREW	VIS	VITE	SCHRAUBE	TORNILLO	
44	900.139.004	1	GASKET	JOINT	GUARNIZIONE	DICHTUNG	JUNTA	
45	900.116.090	1	PLATE	PLAQUE	PIASTRA	PLATTE	PLACA	180-200
46	900.102.018	2	SCREW	VIS	VITE	SCHRAUBE	TORNILLO	180-200
47	900.103.050	2	NUT	ECROU	DADO	MUTTER	TUERCA	180-200

# GPC

## GEARBOX

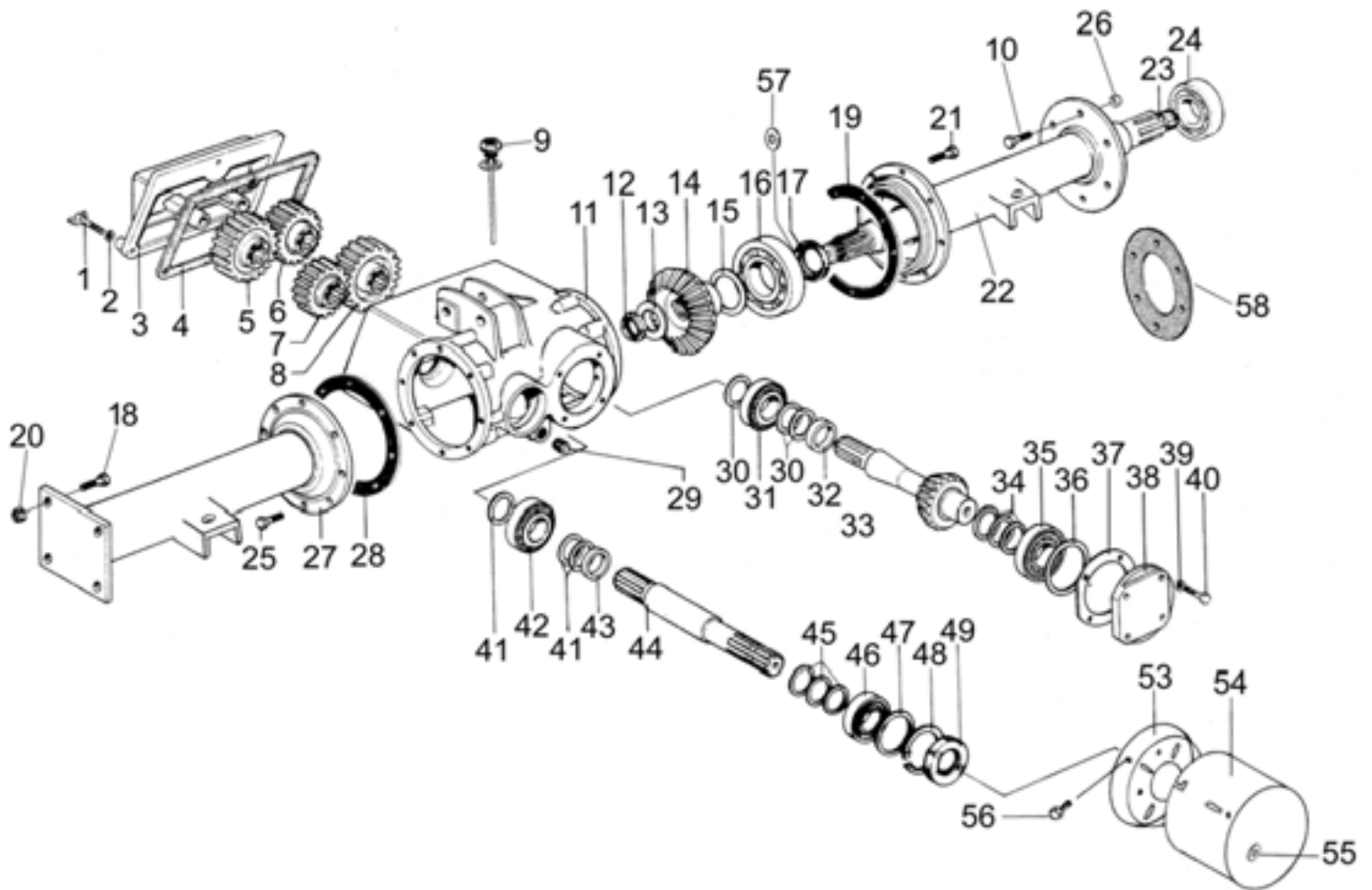

REF	CODE	QTY	ENGLISH	FRANÇAIS	ITALIANO	DEUTSCH	ESPAÑOL	NOTE
1	900.102.055	3	SCREW	VIS	VITE	SCHRAUBE	TORNILLO	
2	900.104.002	3	WASHER	RONDELLE	RONDELLA	ZWISCHENSCHLEIBE	ARANDELA	
3	900.127.016	1	LID	COUVERCLE	COPERCHIO	DECKEL	TAPA	
4	900.139.039	1	GASKET	JOINT	GUARNIZIONE	DICHTUNG	JUNTA	
5	900.127.019	1	GEAR	ENGRENAGE	INGRANAGGIO	ZAHNRAD	ENGRANAJE	
6	900.127.018	1	GEAR	ENGRENAGE	INGRANAGGIO	ZAHNRAD	ENGRANAJE	
7	900.127.017	1	GEAR	ENGRENAGE	INGRANAGGIO	ZAHNRAD	ENGRANAJE	
8	900.127.020	1	GEAR	ENGRENAGE	INGRANAGGIO	ZAHNRAD	ENGRANAJE	
9	900.102.054	1	PLUG	BOUCHON	TAPPO	DECKEL	TAPON	
10	900.102.020	6	SCREW	VIS	VITE	SCHRAUBE	TORNILLO	
11	900.127.010	1	CASE	BOITE	SCATOLA	KISTE	CAJA	
12	900.103.014	1	RING NUT	EMBOUT	GHIERA	NUTMUTTER	CASQUILLO	
13	900.104.012	1	WASHER	RONDELLE	RONDELLA	ZWISCHENSCHLEIBE	ARANDELA	
14	900.127.014	1	CROWN	COURONNE	CORONA	TELLERRAD	CORONA	
15	900.107.028	1	SHIM	EPAISSEUR REG.	SPESSORE REG.	STAERKE	ESPEJOR REG.	
16	900.100.019	1	BEARING	ROULEMENT	CUSCINETTO	KUGELLAGER	COJINETE	
17	900.118.066	1	BUSH	COQUILLE	BOCCOLA	BUCHSE	CASQUILLO	
18	900.102.011	4	SCREW	VIS	VITE	SCHRAUBE	TORNILLO	
19	900.139.041	1	GASKET	JOINT	GUARNIZIONE	DICHTUNG	JUNTA	
20	900.103.002	4	NUT	ECROU	DADO	MUTTER	TUERCA	
21	900.102.019	8	SCREW	VIS	VITE	SCHRAUBE	TORNILLO	
22	900.119.052	1	TUBE	TUBE	CANNOTTO	ROHR	TUBO	140
22	900.119.053	1	TUBE	TUBE	CANNOTTO	ROHR	TUBO	160
22	900.119.054	1	TUBE	TUBE	CANNOTTO	ROHR	TUBO	180
22	900.119.055	1	TUBE	TUBE	CANNOTTO	ROHR	TUBO	200
23	900.118.036.0	1	SHAFT	ARBRE	ALBERO	WELLE	EJE	140
23	900.118.037.0	1	SHAFT	ARBRE	ALBERO	WELLE	EJE	160
23	900.118.038.0	1	SHAFT	ARBRE	ALBERO	WELLE	EJE	180
23	900.118.039.0	1	SHAFT	ARBRE	ALBERO	WELLE	EJE	200
24	900.100.016	1	BEARING	ROULEMENT	CUSCINETTO	KUGELLAGER	COJINETE	
25	900.102.019	8	SCREW	VIS	VITE	SCHRAUBE	TORNILLO	
26	900.103.050	6	NUT	ECROU	DADO	MUTTER	TUERCA	
27	900.123.053	1	DOUBLE TUBE	DOUBLE TUBE	DOPPIO CANNOTTO	DOPPELROHR	DOBLE TUBO	140
27	900.123.054	1	DOUBLE TUBE	DOUBLE TUBE	DOPPIO CANNOTTO	DOPPELROHR	DOBLE TUBO	160
27	900.123.055	1	DOUBLE TUBE	DOUBLE TUBE	DOPPIO CANNOTTO	DOPPELROHR	DOBLE TUBO	180
27	900.123.056	1	DOUBLE TUBE	DOUBLE TUBE	DOPPIO CANNOTTO	DOPPELROHR	DOBLE TUBO	200
28	900.139.041	1	GASKET	JOINT	GUARNIZIONE	DICHTUNG	JUNTA	
29	900.102.051	1	PLUG	BOUCHON	TAPPO	DECKEL	TAPON	
30	900.107.030	3	SHIM	EPAISSEUR REG.	SPESSORE REG.	STAERKE	ESPEJOR REG.	
31	900.100.036	1	BEARING	ROULEMENT	CUSCINETTO	KUGELLAGER	COJINETE	
32	900.107.029	1	SHIM	EPAISSEUR REG.	SPESSORE REG.	STAERKE	ESPEJOR REG.	
33	900.127.012	1	PINION	PIGNON	PIGNONE	RITZEL	PINON	
34	900.107.031	3	SHIM	EPAISSEUR REG.	SPESSORE REG.	STAERKE	ESPEJOR REG.	
35	900.100.024	1	BEARING	ROULEMENT	CUSCINETTO	KUGELLAGER	COJINETE	
36	900.107.010	1	SHIM	EPAISSEUR REG.	SPESSORE REG.	STAERKE	ESPEJOR REG.	
37	900.139.040	1	GASKET	JOINT	GUARNIZIONE	DICHTUNG	JUNTA	
38	900.127.015	1	CLAMPING	CHAPEAU	CAPPELOTTO	KAPPE	CAPUCHON	
39	900.104.003	4	WASHER	RONDELLE	RONDELLA	ZWISCHENSCHLEIBE	ARANDELA	
40	900.102.011	4	SCREW	VIS	VITE	SCHRAUBE	TORNILLO	
41	900.107.032	3	SHIM	EPAISSEUR REG.	SPESSORE REG.	STAERKE	ESPEJOR REG.	
42	900.100.036	1	BEARING	ROULEMENT	CUSCINETTO	KUGELLAGER	COJINETE	
43	900.107.029	1	SHIM	EPAISSEUR REG.	SPESSORE REG.	STAERKE	ESPEJOR REG.	
44	900.127.013	1	SHAFT	ARBRE	ALBERO	WELLE	EJE	
45	900.107.032	3	SHIM	EPAISSEUR REG.	SPESSORE REG.	STAERKE	ESPEJOR REG.	
46	900.100.037	1	BEARING	ROULEMENT	CUSCINETTO	KUGELLAGER	COJINETE	
47	900.107.010	1	SHIM	EPAISSEUR REG.	SPESSORE REG.	STAERKE	ESPEJOR REG.	
48	900.106.009	1	CIRCLIP	SERFLEX	SEEGER	SEEGER	SEEGER	
49	900.101.009	1	OIL SEAL	PARE-HUILE	PARAOILIO	SIMMERRING	PARA-ACEITE	
53	900.117.070	1	PROT. HOLDER	DISQUE	FONDELLO	ZWSCHUTZHALTER	DISCO	
54	900117072.2	1	GUARD	PROTECTION	PROTEZIONE	SCHUTZ	PROTECCION	
55	900.104.010	2	WASHER	RONDELLE	RONDELLA	ZWISCHENSCHLEIBE	ARANDELA	
56	900.102.256	3	SCREW	VIS	VITE	SCHRAUBE	TORNILLO	
57	900.101.079	1	OIL SEAL	PARE-HUILE	PARAOILIO	SIMMERRING	PARA-ACEITE	
58	900.139.004	1	GASKET	JOINT	GUARNIZIONE	DICHTUNG	JUNTA	

# GP GPC

## ROTOR

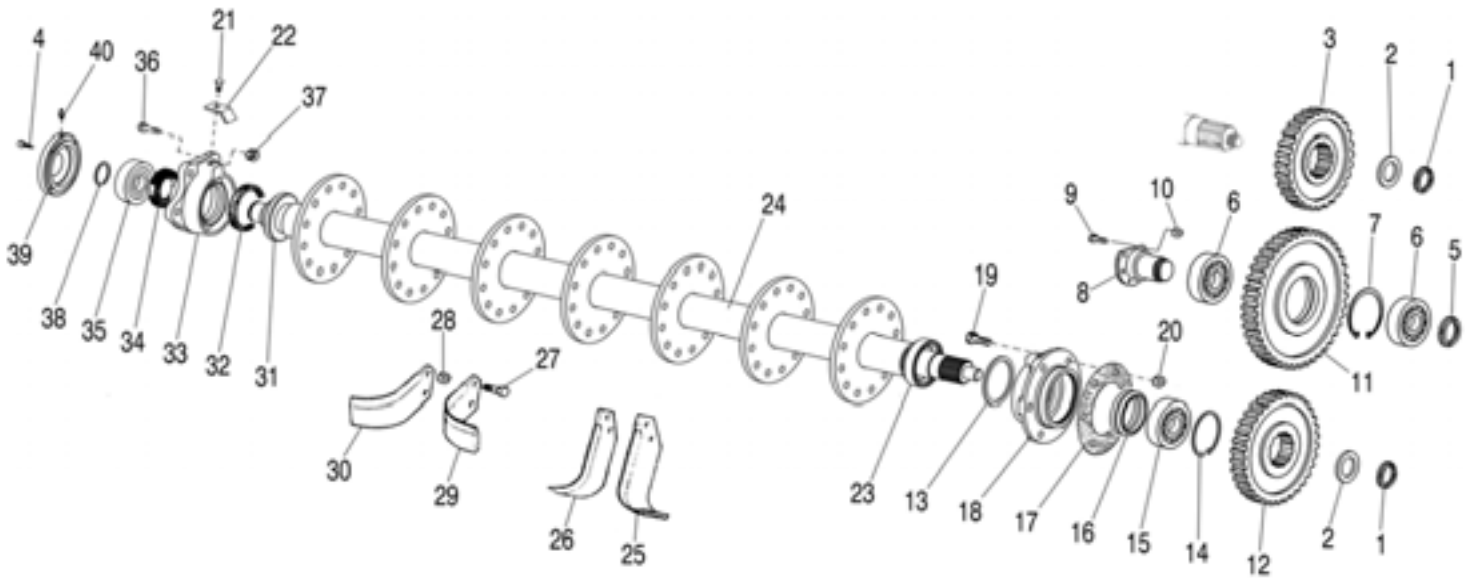

REF	CODE	QTY	ENGLISH	FRANÇAIS	ITALIANO	DEUTSCH	ESPAÑOL	NOTE
1	900.103.030	2	RING NUT	EMBOUT	GHIERA	NUTMUTTER	CASQUILLO	
2	900.104.013	2	WASHER	RONDELLE	RONDELLA	ZWISCHENSCHIBE	ARANDELA	
3	900.112.080	1	GEAR	ENGRENAGE	INGRANAGGIO	ZAHNRAD	ENGRANAJE	
4	900.102.203	4	SCREW	VIS	VITE	SCHRAUBE	TORNILLO	
5	900.103.050	1	RING NUT	EMBOUT	GHIERA	NUTMUTTER	CASQUILLO	
6	900.100.054	2	BEARING	ROULEMENT	CUSCINETTO	KUGELLAGER	COJINETE	
7	900.106.005	1	CIRCLIP	SERFLEX	SEEGER	SEEGER	SEEGER	
8	900.112.083	1	PIN	TOURILLON	PERNO	STIFT	PERNO	
9	900.102.071	5	SCREW	VIS	VITE	SCHRAUBE	TORNILLO	
10	900.103.021	5	NUT	ECROU	DADO	MUTTER	TUERCA	
11	900.112.081	1	GEAR	ENGRENAGE	INGRANAGGIO	ZAHNRAD	ENGRANAJE	
12	900.112.082	1	GEAR	ENGRENAGE	INGRANAGGIO	ZAHNRAD	ENGRANAJE	
13	900.107.022	1	RING	ANNEAU	ANELLO	RING	ANILLO	
14	900.106.005	1	CIRCLIP	SERFLEX	SEEGER	SEEGER	SEEGER	
15	900.100.009	1	BEARING	ROULEMENT	CUSCINETTO	KUGELLAGER	COJINETE	
16	900.101.102	1	WATERPROOF DOUBLE SEAL	DISPOSITIF TENUE	DISPOSITIVO TENUTA	VORRICHTUNG HALTEN	DISPOSITIVO SUJETAR	
17	900.139.004	1	GASKET	JOINT	GUARNIZIONE	DICHTUNG	JUNTA	
18	900.110.153	1	SUPPORT	SUPPORT	SUPPORTO	STUETZE	SOPORTE	
19	900.102.020	6	SCREW	VIS	VITE	SCHRAUBE	TORNILLO	
20	900.103.050	6	NUT	ECROU	DADO	MUTTER	TUERCA	
21	900.102.190	2	SCREW	VIS	VITE	SCHRAUBE	TORNILLO	
22	900.110.043	2	SCRAPER	RACLEUR	RASCHIARULLO	WALZENSCHABER	RASCARODILLO	
23	900.110.152	1	RING	ANNEAU	ANELLO	RING	ANILLO	
24	900.110.065	1	ROTOR	ROTOR	ROTORE	ROTOR	ROTOR	140
24	900.110.066	1	ROTOR	ROTOR	ROTORE	ROTOR	ROTOR	160
24	900.110.067	1	ROTOR	ROTOR	ROTORE	ROTOR	ROTOR	180
24	900.110.068	1	ROTOR	ROTOR	ROTORE	ROTOR	ROTOR	200
25	900.111.004	-	BLADE	LAME	ZAPPETTA	MESSER	AZADA	
26	900.111.003	-	BLADE	LAME	ZAPPETTA	MESSER	AZADA	
27	900.102.045	-	SCREW	VIS	VITE	SCHRAUBE	TORNILLO	
28	900.103.027	-	NUT	ECROU	DADO	MUTTER	TUERCA	
29	900.111.010	-	BLADE	LAME	ZAPPETTA	MESSER	AZADA	
30	900.111.009	-	BLADE	LAME	ZAPPETTA	MESSER	AZADA	
31	900.110.019	1	RING	ANNEAU	ANELLO	RING	ANILLO	
32	900.107.022	1	RING	ANNEAU	ANELLO	RING	ANILLO	
33	900.110.013	1	SUPPORT	SUPPORT	SUPPORTO	STUETZE	SOPORTE	
34	900.101.001.0	1	OIL SEAL	PARE-HUILE	PARAOLIO	SIMMERRING	PARA-ACEITE	
35	900.100.052	1	BEARING	ROULEMENT	CUSCINETTO	KUGELLAGER	COJINETE	
36	900.102.019	4	SCREW	VIS	VITE	SCHRAUBE	TORNILLO	
37	900.103.050	4	NUT	ECROU	DADO	MUTTER	TUERCA	
38	900.106.003	1	CIRCLIP	SERFLEX	SEEGER	SEEGER	SEEGER	
39	900.110.023	1	CLAMPING	CHAPEAU	CAPPELOTTO	KAPPE	CAPUCHON	
40	900.105.007	1	GREASE NIPPLE	GRAISSEUR	INGRASSATORE	SCHMIERNIPPEL	ENGRASADOR	

# LIMITED WARRANTY POLICY



SOVEMA S.r.l., Manufacturer of quality machinery, guarantees new Sovema machinery from the time of delivery to the original purchaser to be free from defects in material and workmanship if properly set up and operated in accordance with recommendations set forth in SOVEMA's operator manual. SOVEMA's liability for any defect of accepted goods shall be limited to replacing them, or as SOVEMA shall elect.

The original purchaser will qualify for the SOVEMA warranty only after they have completed the warranty card in full and forwarded it to SOVEMA S.r.l. Italy or any SOVEMA branch. SOVEMA's obligation shall terminate 12 (twelve) months after the date of purchase of the product by the original purchaser. This warranty cannot be assigned or transferred to anyone unless SOVEMA's consent in writing has first been obtained. All warranty claims must be forwarded to SOVEMA S.p.A. Italy or a SOVEMA branch within 8 (eight) days after occurrence.

The original purchaser will be responsible for and bear costs of :

- A) Normal maintenance such as greasing, maintenance of oil levels, minor adjustments, etc.
- B) Transportation of any kind of, any SOVEMA product to and from the place where warranty work is performed.

This warranty shall not apply to any machine which has been repaired or altered in any way outside the SOVEMA factory which affects its stability or reliability, nor which has been subject to misuse, negligence or accident, nor to any machine that has not been operated in accordance with SOVEMA's printed instructions, or operated beyond the company recommended capacity as per machine.

This warranty shall not be applicable to items which are subject to the warranties of their respective manufacturers. Such items include but are not be limited to clutches, universal joints, knives, hydraulic components, bearings, tires, belts and other trade accessories.

This warranty shall not be applicable to items defined as normal wearing items. Such items include but are not be limited to belts, discs, knives, tines stone guards, tires, slip clutches, pitman shaft, swath sticks, blades or tine holders.

The judgement of SOVEMA S.r.l. in all cases of claims under this warranty shall be final and conclusive and the original purchaser agrees to accept its decisions about all questions as to defects and/or to the exchange of any part or parts.

No Agent, Employee or Representative of SOVEMA has any authority to bind SOVEMA to any affirmation, representation or warranty, concerning its machinery excepts as specifically set forth.

SOVEMA shall not be liable for special or consequential damages of any kind caused by any SOVEMA Product



SOVEMA S.r.l.  
 Via Olmo, 6-8-10  
 41010 Gaggio di Piano (MO)  
 Italy



Telefono: 059 93 85 85  
 Fax : 059 93 85 12  
 E-mail : [sovema@sovema.com](mailto:sovema@sovema.com)  
 Web site: [www.sovema.com](http://www.sovema.com)

## WARRANTY REGISTRATION

This warranty will become valid only if this form is completed and signed by both the Purchaser and the Dealer and is returned within 8 days of purchase date! IF NOT WARRANTY IS INVALID.

### TO FILL OUT

- ❖ *TYPE OF IMPLEMENT* : \_\_\_\_\_
- ❖ *SERIAL NUMBER* : \_\_\_\_\_
- ❖ *DATE OF PURCHASE* : \_\_\_\_\_

<p><b>DEALER: I HEREBY CERTIFY THAT:</b></p> <ul style="list-style-type: none"> <li>The machine has been correctly assembled in accordance with the manufacturer's instructions.</li> <li>All nuts and bolts, oil level and grease have been checked.</li> <li>All safety guards and warning stickers have been placed on the machine.</li> <li>PTO has been matched to tractor and greased.</li> <li>All other pre-delivery checks have been completed as per operator's manual.</li> <li>The Customer has received the manual and has been instructed on safe and correct usage of the machine</li> <li>Machine was tested and operates correctly.</li> </ul>	<p><b>PURCHASER: I HEREBY ACCEPT</b></p> <ul style="list-style-type: none"> <li>That the machine is correctly assembled</li> <li>That I received the operator's manual and I have read it and correctly understood.</li> <li>To have a clear understanding of the warranty limitations</li> <li>To have a clear understanding of the correct and safe operation of the machine.</li> <li>That the machine needs regular maintenance as instructed in the operator's manual</li> <li>To have clearly understood the functioning and the limitations of the machine.</li> </ul>
---	---

<table style="width: 100%; border-collapse: collapse;"> <tr> <td style="width: 20px; text-align: center; vertical-align: middle;"><b>DEALER</b></td> <td style="border: none;">(Address) _____ _____ _____ Date: _____ Signature: _____</td> </tr> </table>	<b>DEALER</b>	(Address) _____ _____ _____ Date: _____ Signature: _____	<table style="width: 100%; border-collapse: collapse;"> <tr> <td style="width: 20px; text-align: center; vertical-align: middle;"><b>CUSTOMER</b></td> <td style="border: none;">(Address) _____ _____ _____ Date: _____ Signature: _____</td> </tr> </table>	<b>CUSTOMER</b>	(Address) _____ _____ _____ Date: _____ Signature: _____
<b>DEALER</b>	(Address) _____ _____ _____ Date: _____ Signature: _____				
<b>CUSTOMER</b>	(Address) _____ _____ _____ Date: _____ Signature: _____				

**COPY TO DELIVER TO: SOVEMA Srl**





SOVEMA S.r.l.  
 Via Olmo, 6-8-10  
 41010 Gaggio di Piano (MO)  
 Italy



Telefono: 059 93 85 85  
 Fax : 059 93 85 12  
 E-mail : [sovema@sovema.com](mailto:sovema@sovema.com)  
 Web site: [www.sovema.com](http://www.sovema.com)

## WARRANTY REGISTRATION

This warranty will become valid only if this form is completed and signed by both the Purchaser and the Dealer and is returned within 8 days of purchase date! IF NOT WARRANTY IS INVALID.

### TO FILL OUT

- ❖ *TYPE OF IMPLEMENT* : \_\_\_\_\_
- ❖ *SERIAL NUMBER* : \_\_\_\_\_
- ❖ *DATE OF PURCHASE* : \_\_\_\_\_

<p><b>DEALER: I HEREBY CERTIFY THAT:</b></p> <ul style="list-style-type: none"> <li>The machine has been correctly assembled in accordance with the manufacturer's instructions.</li> <li>All nuts and bolts, oil level and grease have been checked.</li> <li>All safety guards and warning stickers have been placed on the machine.</li> <li>PTO has been matched to tractor and greased.</li> <li>All other pre-delivery checks have been completed as per operator's manual.</li> <li>The Customer has received the manual and has been instructed on safe and correct usage of the machine</li> <li>Machine was tested and operates correctly.</li> </ul>	<p><b>PURCHASER: I HEREBY ACCEPT</b></p> <ul style="list-style-type: none"> <li>That the machine is correctly assembled</li> <li>That I received the operator's manual and I have read it and correctly understood.</li> <li>To have a clear understanding of the warranty limitations</li> <li>To have a clear understanding of the correct and safe operation of the machine.</li> <li>That the machine needs regular maintenance as instructed in the operator's manual</li> <li>To have clearly understood the functioning and the limitations of the machine.</li> </ul>
---	---

<table style="width: 100%; border-collapse: collapse;"> <tr> <td style="width: 20px; text-align: center; vertical-align: middle;"><b>DEALER</b></td> <td style="border: none;">(Address) _____ _____ _____ Date: _____ Signature: _____</td> </tr> </table>	<b>DEALER</b>	(Address) _____ _____ _____ Date: _____ Signature: _____	<table style="width: 100%; border-collapse: collapse;"> <tr> <td style="width: 20px; text-align: center; vertical-align: middle;"><b>CUSTOMER</b></td> <td style="border: none;">(Address) _____ _____ _____ Date: _____ Signature: _____</td> </tr> </table>	<b>CUSTOMER</b>	(Address) _____ _____ _____ Date: _____ Signature: _____
<b>DEALER</b>	(Address) _____ _____ _____ Date: _____ Signature: _____				
<b>CUSTOMER</b>	(Address) _____ _____ _____ Date: _____ Signature: _____				

**PURCHASER'S COPY**

# SOVEMA Product Line

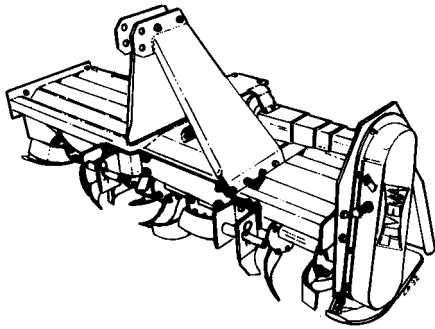

## SIDE SHIFT ROTARY TILLERS

- 15 different models;
- for tractors from 12 to 70 HP
- Working widths from 80 to 200 cm.

## FIXED ROTARY TILLERS

- Over 45 different models;
- For tractors from 15 to 130 HP
- Working width from 80 to 300 cm.

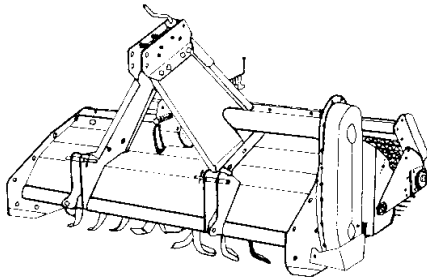
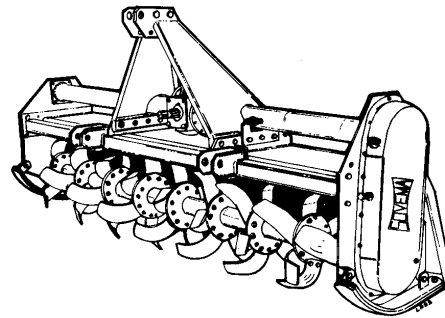

## STONE BURIERS

- 6 different models;
- For tractors from 35 to 90 HP
- Working width from 100 to 200 cm.

## ROTARY HARROWS

- 13 different models;
- For tractors from 25 to 150 HP
- Working width from 110 to 500 cm.

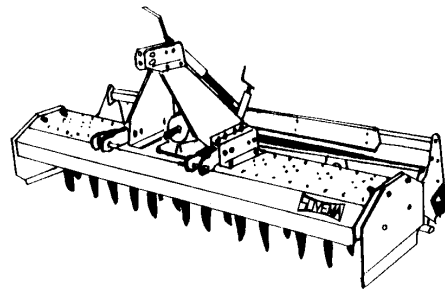

## DITCHERS

- 10 different models;
- For tractors from 40 to 130 HP
- Working width from 45 to 110 cm.

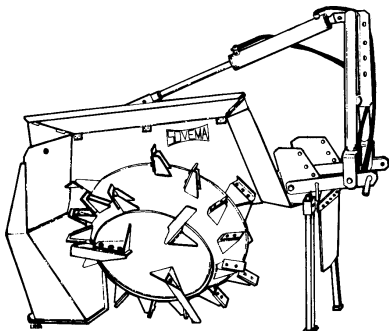

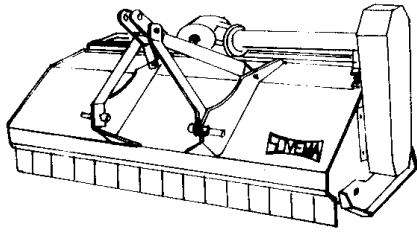

### FLAIL MOWERS—SHREDDERS

- 35 different models;
- For tractors from 15 to 120 HP
- Working width from 100 to 470 cm.

### MOWERS—COLLECTORS

- 6 different models;
- for tractors from 30 to 60 HP
- Working width from 120 to 180 cm.
- Available with high or low discharge

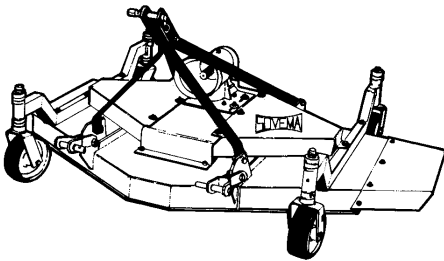
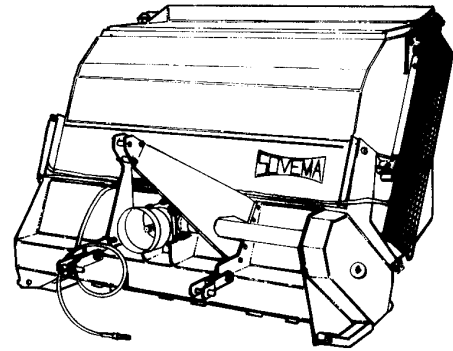

### FINISHING MOWERS

- 14 different models;
- for tractors from 15 to 70 HP
- Working width from 100 to 300 cm.

### HYDRAULIC FORK-LIFTS

- 11 different models;
- For tractors from 60 HP
- Lifting capacity from 1.300 Kg. to 2.000 Kg.

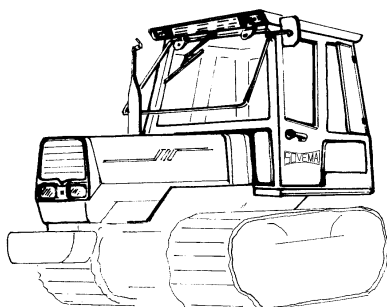
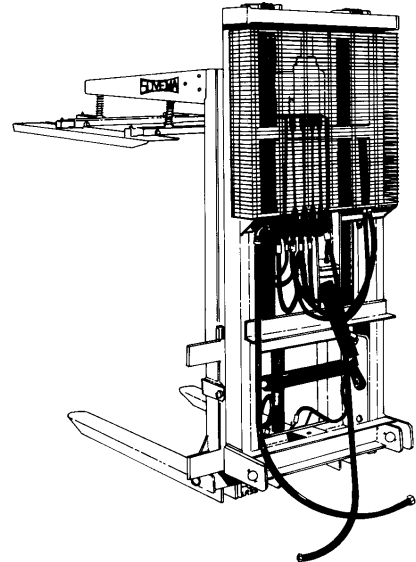

### TRACTOR CABS

- More than 20 cab models for eleven tractor manufacturers;
- For tractors with wheels or crawlers;
- All models available with heating and/or air conditioned

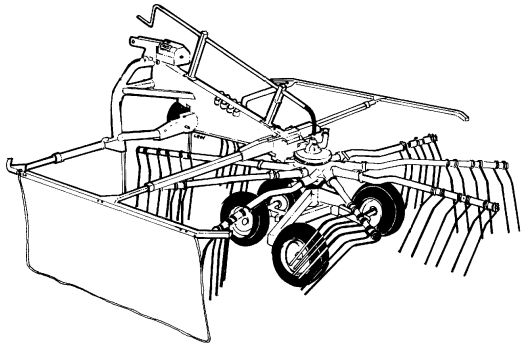

### **ROTARY RAKE**

- 4 different models
- For tractors from 30 to 70 HP
- Working width from 340 to 695 cm

### **HAY TEDDERS**

- 6 different models (2, 4 e 6 rotors)
- For tractors from 10 to 40 HP
- Working width from 310 to 730 cm

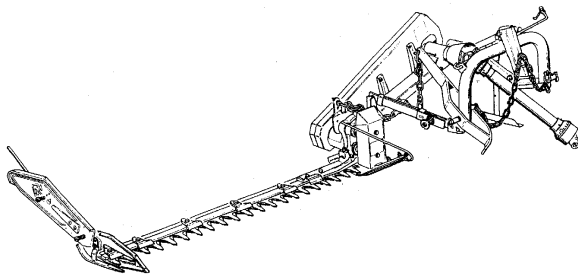
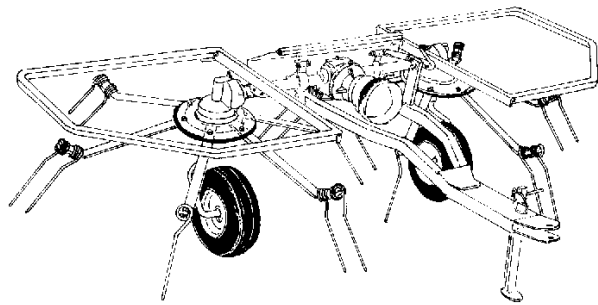

### **SICKLE BAR MOWERS**

- 3 different models
- For tractors from 10 to 15 HP

### **FINGER WHEELS—V-RAKES**

- 8 different models (8-20 rakes)
- For tractors from 30 to 80 HP
- Working width from 7,35 to 12,50 m

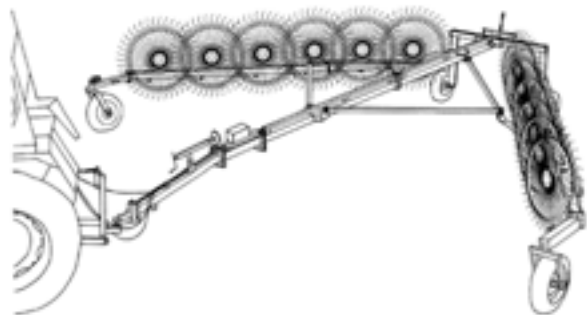

**SOVEMA S.r.l.**

Via Olmo, 6

41013 Gaggio di Piano (MO) – ITALIA

Tél. +39 059 93 85 85 - Fax +39 059 93 85 12

E-Mail: [sovema@sovema.com](mailto:sovema@sovema.com)

WEB Site: <http://www.sovema.com>

**SOVEMA-AGRITAL Cabs**

Via Leonardo da Vinci, 20

24040 Arzago d'Adda (BG) – ITALIA

Tél. +39 0363 87 633 - Fax +39 0363 87 355

E-Mail: [agrital@agritalsovema.com](mailto:agrital@agritalsovema.com)

WEB Site: <http://www.agrital.com>

**SOVEMA Inc.**

1937 Vanderhorn Drive

Memphis, TN 38134 USA

Ph. 901 388 8869 - Fax 901 388 8348

E-Mail: [sovema@sovemausa.com](mailto:sovema@sovemausa.com)

WEB Site: <http://www.sovemausa.com>

**SOVEMA CANADA Ltd.**

4845 Portage Avenue

Headingley, MB R4H 1C7 CANADA

Ph. 204 927 9042 - Fax 204 897 6975

E-Mail: [sovema@sovemaCanada.com](mailto:sovema@sovemaCanada.com)

WEB Site: <http://www.sovemaCanada.com>