

1140 Basic Line

Hoftrac



WEIDEMANN
designed for work



1140 Basic Line Technical specifications

Engine data

Manufacturer	Perkins
Engine type	403 J-11
Cylinders	3
Engine performance	18.4 (25) kW (hp)
at rpm (max.)	2800 rpm
Cubic capacity	1131 cm ³
Cooling system	Water
Emissions standard level	V
Exhaust after treatment	-

Electrical system

Operating voltage	12 V
Alternator	40 A
Weights	
Operating weight (standard)	1630 kg
Tipping load with bucket - machine straight	664-733* kg
Tipping load with bucket - machine articulated	490-554* kg
Tipping load with pallet fork - machine straight	532-538* kg
Tipping load with pallet fork - machine articulated	391-398* kg
Vehicle data	
Axle (optional)	K75 (K90)
Cab (optional)	FSD (eps)
Ground speed (optional)	0-12 (13) km/h
Speed stages	1
Fuel tank capacity	21 l
Hydraulic oil tank capacity	18 l
Hydraulic system	
External services - Operating pressure (optional)	215 (305) bar
Steering hydraulics - Oil flow	30.8 l/min
Steering hydraulics - Operating pressure	205 bar
Drive	
Type of drive (optional)	hydraulically activated (hydrostatic)
Traction drive	Oil engine
Noise values	
Average sound power level L _{WA}	99.7 dB(A)
Guaranteed sound power level L _{WA}	101 dB(A)
Specified sound pressure level L _{pA}	85 dB(A)

*Tipping load with counterweight

Tipping load calculation according to ISO 14397

FSD = overhead guard

eps = Easy Protection System (fold-down overhead guard)

Vibrations (weighted average effective value)

Hand-arm vibrations (HAV):

The hand-arm vibrations are no more than 2.5 m/s²

Whole body vibrations:

This machine is equipped with a driver's seat that meets the requirements of EN ISO 7096:2000.

When the loader is properly used, the whole body vibrations vary from below 0.5 m/s² up to a short-term maximum value.

It is recommended to use the values specified in the table when calculating the vibration values according to ISO/TR 25398:2006. At the same time the actual use conditions have to be taken into consideration.

Tele wheel loaders, like wheel loaders, are to be classified by operating weight.

Type of loader	Typical operating conditions	Average value			Standard deviation (s)		
		$1.4 \cdot a_{w,eqx}$ [m/s ²]	$1.4 \cdot a_{w,eqy}$ [m/s ²]	$a_{w,eqz}$ [m/s ²]	$1.4 \cdot s_x$ [m/s ²]	$1.4 \cdot s_y$ [m/s ²]	s_z [m/s ²]
Compact wheel loader (operating weight < 4,500 kg)	Load & carry (load and transport work)	0.94	0.86	0.65	0.27	0.29	0.13
Wheel loader (operating weight > 4,500 kg)	Load & carry (load and transport work)	0.84	0.81	0.52	0.23	0.2	0.14
	Application in extraction (harsh application conditions)	1.27	0.97	0.81	0.47	0.31	0.47
	Transfer drive	0.76	0.91	0.49	0.33	0.35	0.17
	V-operation	0.99	0.84	0.54	0.29	0.32	0.14

1140 Basic Line

Hoftrac

1140 Basic Line Dimensions

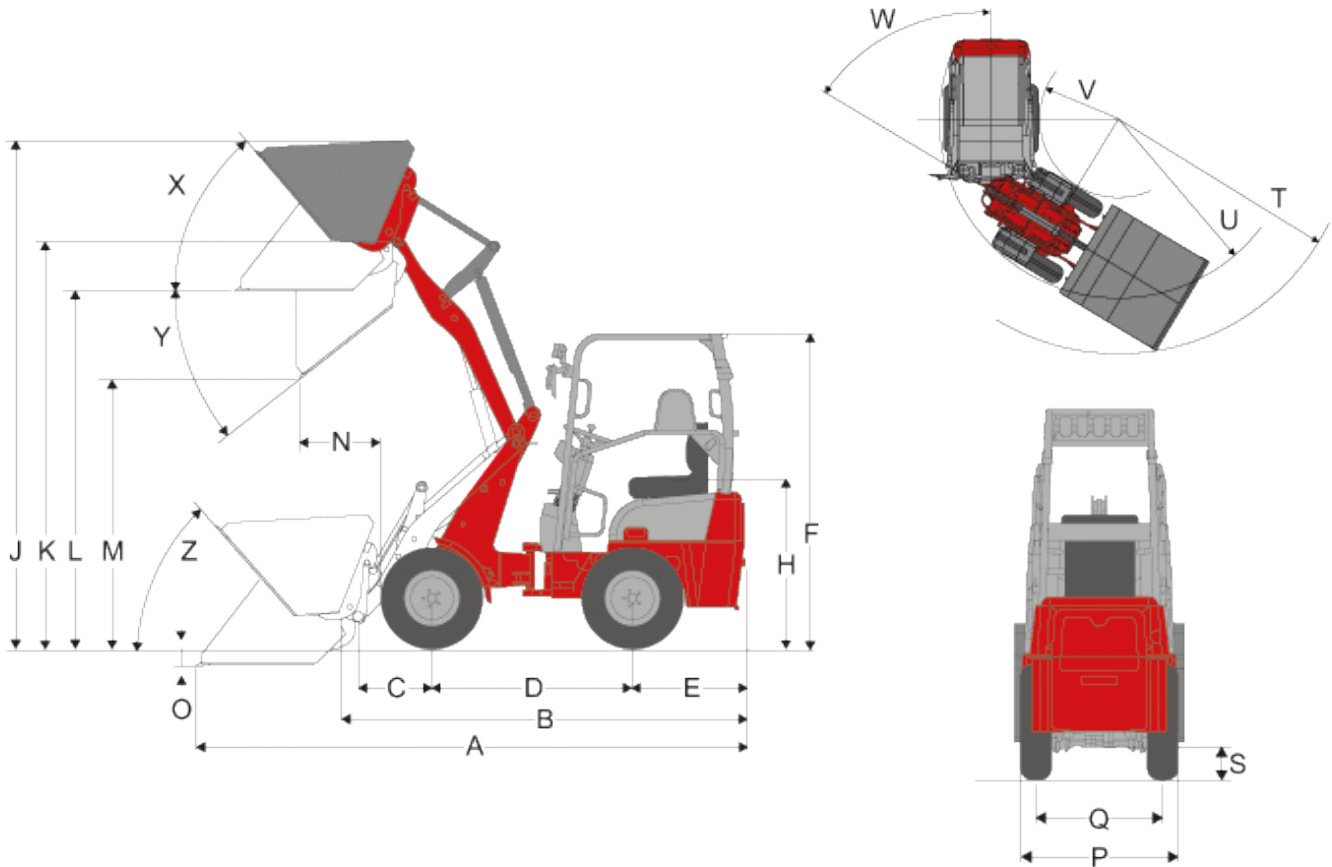

A	Total length	3,706 mm
B	Total length (without bucket)	2,733 mm
C	Axle middle to bucket pivot pin	496 mm
D	Wheelbase	1,345 mm
E	Rear overhang	779 mm
F	Height to top of overhead guard fixed	2,124 mm
	Height to top of overhead guard foldable (eps)	2,227 mm
	Height to top of overhead guard foldable, folded (eps)	1,937 mm
H	Seat top height	1,142 mm
J	Total working height	3,415 mm
K	Height of bucket pivot (max.)	2,734 mm
L	Load-over height	2,405 mm
M	Dumping height	1,807 mm
N	Operating distance for M	550 mm
O	Digging depth	113 mm
P	Total width	850 mm
Q	Track width	660 mm

S	Ground clearance	190 mm
T	Maximum radius external	2,140 mm
U	Radius at the outer edge	1,570 mm
V	Inside turning radius	600 mm
W	Inclination angle	55 °
X	Rollback angle at max. lifting height	50 °
Y	Dumping angle (max.) (max.)	39 °
Z	Rollback angle (on the ground)	48 °

eps (Easy Protection System) = fold-down overhead guard

1140 Basic Line

Hoftrac

1140 Basic Line Standard components

Motor

- Perkins 403 J-11 (18,4 kW / 25 HP), Stage V

Drive system

- Compact axle K75
- Automatic drive via oil engines on the axles, travel direction can be selected via the drive pedal
- Service brake: Gear drum brake acting on rear axle
- Central service and parking brake in the drive train acting on all 4 wheels
- Tyres 7.00-12 AS ET40

Steering system

- Hydraulic articulated pendulum steering, 12° oscillating angle

Hydraulics

- 3rd Control circuit front DN10
- Lock for steering valve
- Floating position for lift and tilting cylinders

Driver's cabin

- Overhead guard with retaining system ROPS/FOPS tested

Other

- Operating hour meter
- Fuel display
- Mechanical quick-change system for attachments

1140 Basic Line

Hoftrac

1140 Basic Line Options

Driver's cabin

- eps (Easy Protection System): fold-down overhead guard
- Adjustable steering column
- Rear-view mirror (left and right)

Lighting

- Working lights, 2 front, 1 rear
- Working light on loading arm
- Lighting according to Road Traffic Regulations
- Rotating beacon

Axles/drive

- K90 (hydraulically activated all-wheel drive)
- K75 (hydrostatic all-wheel drive)
- K90 (hydrostatic all-wheel drive)

Hydraulics

- 3rd comfort control circuit
- Hydraulic oil cooler
- Notch for joystick (single)

Other

- Hydraulic quick-change system for attachments
- Ballast weight (rear mounting)

Please note: that product availability can vary from country to country. It is possible that information / products may not be available in your country. More detailed information on engine power can be found in the operator's manual; the stated power may vary due to specific operating conditions. Subject to alterations and errors excepted. Applicable also to illustrations.

Copyright © 2022 Weidemann GmbH.