

# 1280 Hoftrac



**WEIDEMANN**  
*designed for work*



## 1280 Technical specifications

### Engine data

Manufacturer	Perkins
Engine type	403 J-17
Cylinders	3
Engine performance	18.4 ( 25 ) kW (hp)
at rpm (max.)	2800 rpm
Cubic capacity	1508 cm <sup>3</sup>
Cooling system	Water
Emissions standard level	V
Exhaust after treatment	-

### Electrical system

Operating voltage	12 V
Alternator	65 A
<b>Weights</b>	
Operating weight (standard)	2380-2550* kg
Tipping load with bucket - machine straight	1385-1781* kg
Tipping load with bucket - machine articulated	1154-1478* kg
Tipping load with pallet fork - machine straight	1081-1401* kg
Tipping load with pallet fork - machine articulated	981-1152* kg
<b>Vehicle data</b>	
Axle	T94
Cab (optional)	FSD (eps, cabin)
Ground speed	0 - 20 km/h
Speed stages	2
Fuel tank capacity	45 l
Hydraulic oil tank capacity	27 l
<b>Hydraulic system</b>	
External services - Operating pressure	370 bar
Steering hydraulics - Oil flow	44.8 l/min
Steering hydraulics - Operating pressure	185 bar
<b>Drive</b>	
Type of drive	Hydrostatic
Traction drive	Universal joint shaft
<b>Noise values</b>	
Average sound power level L <sub>WA</sub>	99.7 dB(A)
Guaranteed sound power level L <sub>WA</sub>	101 dB(A)
Specified sound pressure level L <sub>pA</sub>	82 dB(A)

\*Tipping load with counterweight (base plate) and cast rear weight

Tipping load calculation according to ISO 14397

FSD = canopy

eps = Easy Protection System (fold-down canopy)

---

Vibrations (weighted average effective value)

**Hand-arm vibrations:** The hand-arm vibrations are no more than 2.5 m/s<sup>2</sup>

**Whole body vibrations:** This machine is equipped with a driver's seat that meets the requirements of EN ISO 7096:2000.

When the loader is properly used, the whole body vibrations vary from below 0.5 m/s<sup>2</sup> up to a short-term maximum value.

It is recommended to use the values specified in the table when calculating the vibration values according to ISO/TR 25398:2006. At the same time the actual use conditions have to be taken into consideration.

Telescopic loaders, like wheel loaders, are to be classified by operating weight.

Type of loader	Typical operating conditions	Average value			Standard deviation (s)		
		$1.4 \cdot a_{w,eqx}$ [m/s <sup>2</sup> ]	$1.4 \cdot a_{w,eqy}$ [m/s <sup>2</sup> ]	$a_{w,eqz}$ [m/s <sup>2</sup> ]	$1.4 \cdot s_x$ [m/s <sup>2</sup> ]	$1.4 \cdot s_y$ [m/s <sup>2</sup> ]	$s_z$ [m/s <sup>2</sup> ]
Compact wheel loader (operating weight < 4,500 kg)	Load & carry (load and transport work)	0.94	0.86	0.65	0.27	0.29	0.13
Wheel loader (operating weight > 4,500 kg)	Load & carry (load and transport work)	0.84	0.81	0.52	0.23	0.2	0.14
	Application in extraction (harsh application conditions)	1.27	0.97	0.81	0.47	0.31	0.47
	Transfer drive	0.76	0.91	0.49	0.33	0.35	0.17
	V-operation	0.99	0.84	0.54	0.29	0.32	0.14

1280 Dimensions

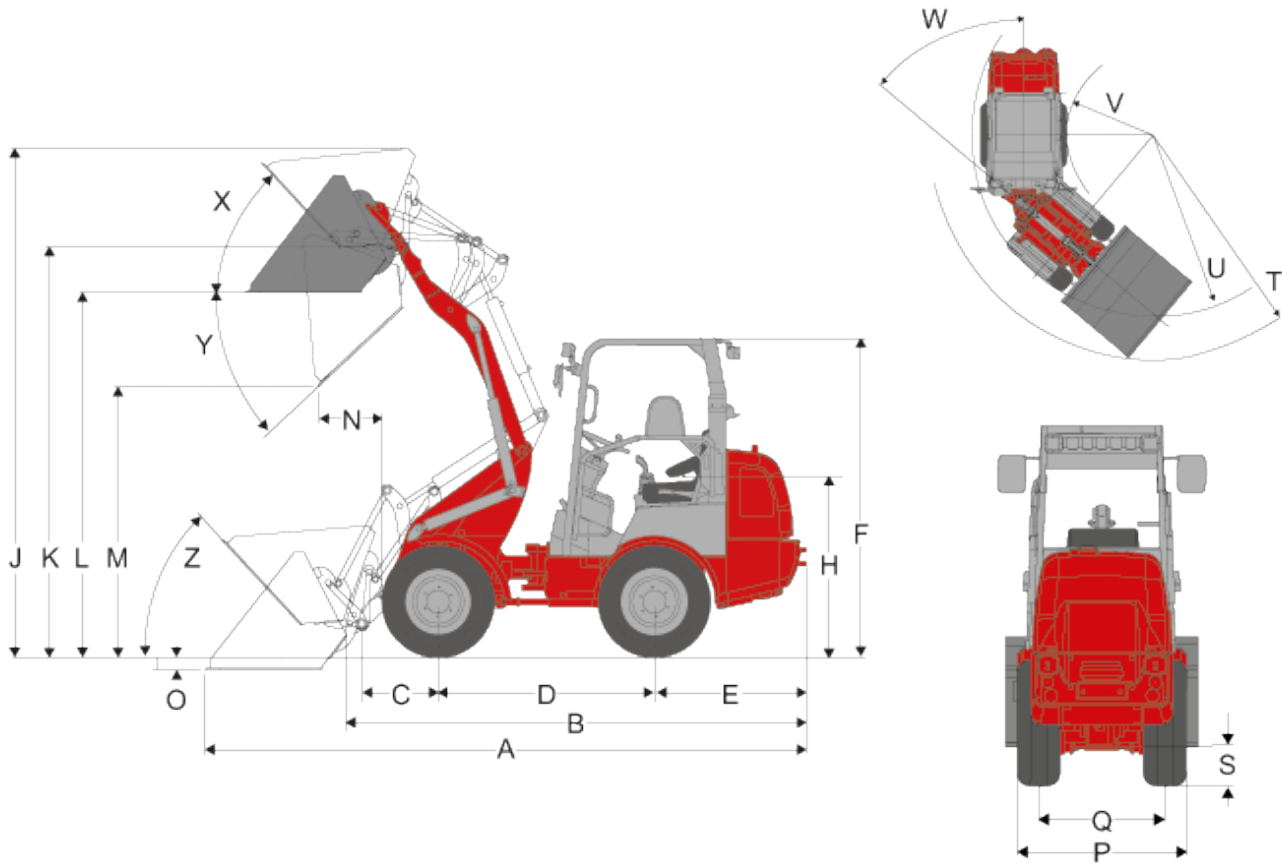

A	Total length	4,248 mm
B	Total length (without bucket)	3,270 mm
C	Axle middle to bucket pivot pin	531 mm
D	Wheelbase	1,623 mm
E	Rear overhang	1,000 mm
F	Height to top of overhead guard fixed	2,184 mm
	Height to top of overhead guard foldable (eps)	2,298 mm
	Height to top of overhead guard foldable, folded (eps)	1,780 mm
	Height to top of cabin	2,280 mm
H	Seat top height	1,259 mm
J	Total working height	3,545 mm
K	Height of bucket pivot (max.)	2,860 mm
L	Load-over height	2,541 mm
M	Dumping height	1,884 mm
N	Operating distance for M	447 mm
O	Digging depth	81 mm
P	Total width	1,044 mm

Q	Track width	780 mm
S	Ground clearance	250 mm
T	Maximum radius external	2,918 mm
U	Radius at the outer edge	2,541 mm
V	Inside turning radius	1,423 mm
W	Inclination angle	45 °
X	Rollback angle at max. lifting height	47 °
Y	Dumping angle (max.) (max.)	43 °
Z	Rollback angle (on the ground)	47 °

eps (Easy Protection System) = fold-down canopy

## 1280

Hoftrac

### 1280 Standard components

#### Engine

- Perkins 403 J-17 (18,4 kW / 25 HP), Stage V

#### Drive

- Compact axle T94
- Hydrostatic all-wheel drive, travel direction can be selected via joystick
- Service brake: Hydrostatic drive system acting on all 4 wheels (wear-free)
- Central service and parking brake in the drive train acting on all 4 wheels
- Tyres 10.0 / 75 - 15.3 AS ET80

#### Steering

- Hydraulic articulated pendulum steering, 12° oscillating angle

#### Hydraulics

- 3rd Control circuit front DN10
- Hydraulic oil cooler
- Lock for steering valve
- Floating position for lift and tilting cylinders

#### Driver's cab

- Canopy with retaining system ROPS / FOPS tested, driver's cab can be tilted to the side
- Comfort seat with safety belt, fully suspended, weight, back and horizontal adjustment, 60 mm spring deflection
- Joystick with travel direction switch
- Adjustable steering column

#### Other

- Working lights (2 front, 2 rear)
- Operating hour meter

- Battery circuit breaker
- Fuel display
- Mechanical quick-change system for attachments

## 1280

Hoftrac

### 1280 Options

Driver's cab

- Right armrest
- eps (Easy Protection System) - fold-down canopy
- 2-door cabin, including heating and ventilation
- Air-suspended comfort seat

Lighting

- Working light on loading arm
- Lighting according to Road Traffic Regulations
- Rotary beacon

Drive

- T94 including transfer gear and universal joint shaft (high pressure drive system)
- 100% differential lock
- Hand inching (creep speed controller)

Hydraulics

- Unpressurised reflux (front / rear)
- 3rd control circuit front DN12
- 3rd comfort control circuit
- 4th comfort control circuit
- Faster plug-in connector (machine or attachment side)
- Notch for joystick (single / double)
- Hydraulic connection in rear (single-acting or dual-acting)
- Three-point rear tool holder

Electrical connections

- Plug receptacle in front, triple-pole (single or dual function)
- Plug receptacle for rear attachments, 7-pin



## Other

- Engine pre-heating
- Radio
- High lifting height
- Hydraulic quick-change system for attachments
- Counterweight (floor panel)
- Weight of cast iron rear
- Back-up alarm
- Load-lowering valve
- Combination case with warning triangle and first-aid kit
- Switch position indicator
- Self-recovery coupling
- Tool box
- Technical Inspection Authority expert's report
- Fully automatic central lubrication unit
- Custom made paint finish
- Hand lever grease gun

Please note: that product availability can vary from country to country. It is possible that information / products may not be available in your country. More detailed information on engine power can be found in the operator's manual; the stated power may vary due to specific operating conditions. Subject to alterations and errors excepted. Applicable also to illustrations.

Copyright © 2022 Weidemann GmbH.