

# 3080LP

## Wheel loader



**WEIDEMANN**  
*designed for work*



### 3080LP Technical specifications

#### Engine data Standard

Manufacturer	Deutz
Engine type	TD 2.9 L4 S5
Cylinders	4
Engine performance	45 (61) kW (hp)
at rpm (max.)	2300 rpm
Cubic capacity	2900 cm <sup>3</sup>
Cooling system	Water
Emissions standard level	V
Exhaust after treatment	DPF / DOC

#### Engine data (optional)

Manufacturer	Deutz
Engine type	TCD 2.9 L4 S5
Cylinders	4
Engine performance	55.4 (75) kW (hp)
at rpm (max.)	2300 rpm
Cubic capacity	2900 cm <sup>3</sup>
Cooling system	Water / Charge air
Emissions standard level	V
Exhaust after treatment	DPF / DOC
<b>Electrical system</b>	
Operating voltage	12 V
Alternator	85 A
<b>Weights</b>	
Operating weight (standard)	4600 kg
Tipping load with bucket - machine straight	2626 kg
Tipping load with bucket - machine articulated	2173-2677 kg
Tipping load with pallet fork - machine straight	2258 kg
Tipping load with pallet fork - machine articulated	1896-2259 kg
<b>Vehicle data</b>	
Axle (optional)	PA 1400
Cab (optional)	FSD (cabin)
Ground speed (optional)	0-20 (30) km/h
Speed stages	2
Fuel tank capacity	82 l
Hydraulic oil tank capacity	66 l
<b>Hydraulic system</b>	
External services - Operating pressure	450 bar
Steering hydraulics - Oil flow (optional)	64,4 (74-115) l/min
Steering hydraulics - Operating pressure	210 bar
<b>Drive</b>	
Type of drive	Hydrostatic
Traction drive	Universal joint shaft
<b>Noise values</b>	
Guaranteed sound power level L <sub>WA</sub>	101 dB(A)

Tipping load calculation according to ISO 14397

FSD = overhead guard

---

Vibrations (weighted average effective value)

**Hand-arm vibrations (HAV):** The hand-arm vibrations are no more than 2.5 m/s<sup>2</sup>

**Whole body vibrations:** This machine is equipped with a driver's seat that meets the requirements of EN ISO 7096:2000.

When

the loader is in accordance with the intended purpose, the whole body

vibrations vary from below 0.5 m/s<sup>2</sup> up to a short-term

maximum value.

It is recommended to use the values

specified in the table when calculating the vibration values

according to ISO/TR 25398:2006. At the same time the actual use conditions have to be taken into

consideration.

Tele wheel loaders, like wheel loaders, are to be classified by operating weight.

Type of loader	Typical operating conditions	Average value			Standard deviation (s)		
		1.4*a <sub>w,eqx</sub>	1.4*a <sub>w,eqy</sub>	a <sub>w,eqz</sub>	1.4*s <sub>x</sub>	1.4*s <sub>y</sub>	s <sub>z</sub>
		[m/s <sup>2</sup> ]	[m/s <sup>2</sup> ]	[m/s <sup>2</sup> ]	[m/s <sup>2</sup> ]	[m/s <sup>2</sup> ]	[m/s <sup>2</sup> ]
Compact wheel loader (operating weight < 4,500 kg)	Load & carry (load and transport work)	0.94	0.86	0.65	0.27	0.29	0.13
Wheel loader (operating weight > 4,500 kg)	Load & carry (load and transport work)	0.84	0.81	0.52	0.23	0.2	0.14
	Application in extraction (harsh application conditions)	1.27	0.97	0.81	0.47	0.31	0.47
	Transfer drive	0.76	0.91	0.49	0.33	0.35	0.17
	V-operation	0.99	0.84	0.54	0.29	0.32	0.14

3080LP  
Wheel loader

3080LP Dimensions

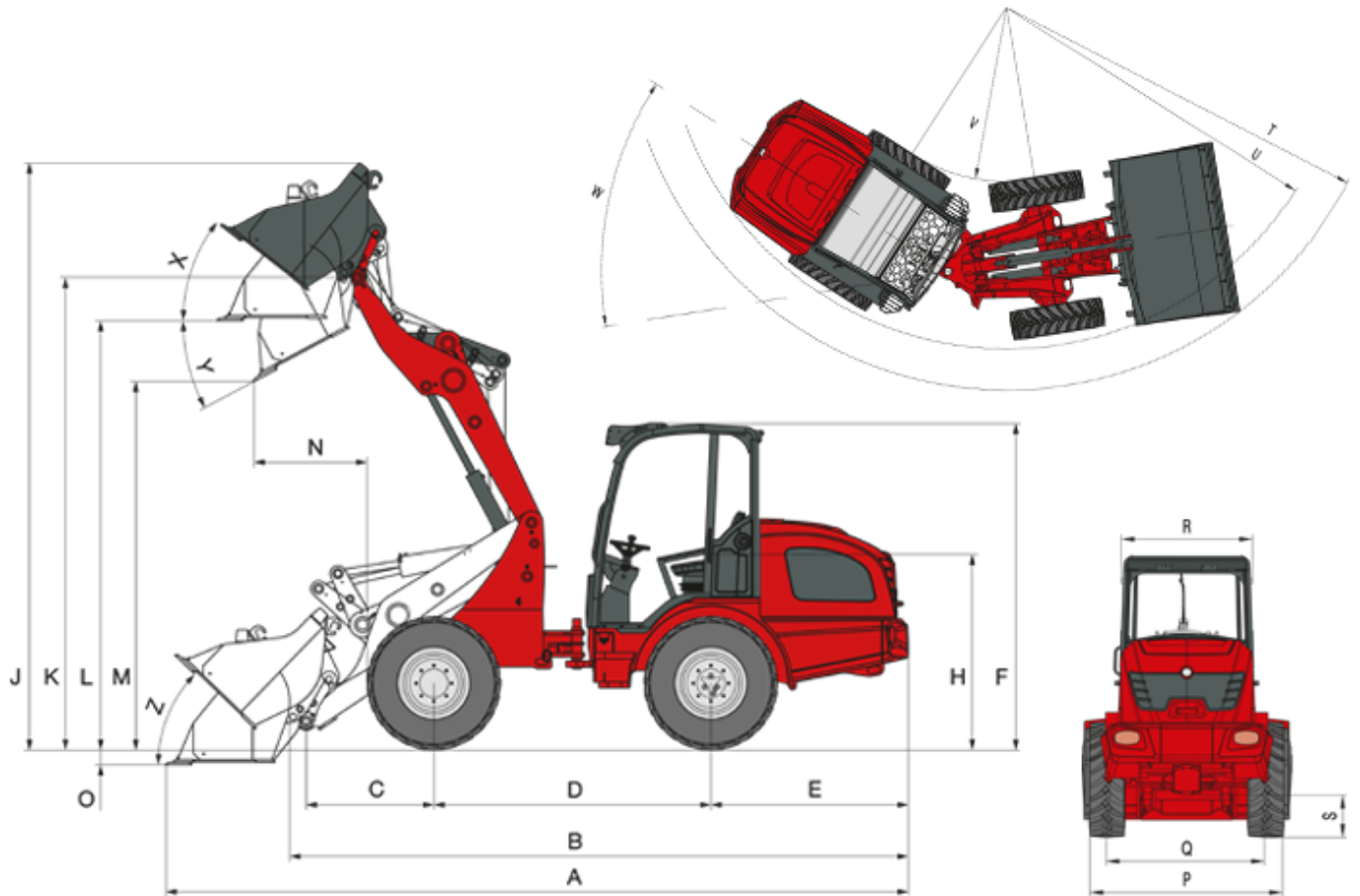

A	Total length	5,542 mm
B	Total length (without bucket)	4,647 mm
C	Axle middle to bucket pivot pin	1027 mm
D	Wheelbase	2,005 mm
E	Rear overhang	1,531 mm
F	Height to top of overhead guard - low-profile	2,313 mm
	Height to top of overhead guard - high-profile	2,471 mm
	Height to top of cabin - low-profile	2,313 mm
	Height to top of cabin - high-profile	2,513 mm
H	Seat top height	1,470 mm
J	Total working height	4,056 mm
K	Height of bucket pivot (max.)	3,352 mm
L	Load-over height	3,019 mm
M	Dumping height	2,474 mm
N	Operating distance for M	694 mm
O	Digging depth	123 mm
P	Total width	1,663 mm

Q	Track width	1,383 mm
S	Ground clearance	357 mm
T	Maximum radius external	4,105 mm
U	Radius at the outer edge	3,587 mm
V	Inside turning radius	1,753 mm
W	Inclination angle	42 °
X	Rollback angle at max. lifting height	43 °
Y	Dumping angle (max.) (max.)	39 °
Z	Rollback angle (on the ground)	42 °

## 3080LP

Wheel loader

### 3080LP Standard components

Motor

- Deutz TD 2.9 L4 S5 (45 kW / 61 HP), Stage V

Drive system

- Planetary axle PA1400
- Hydrostatic all-wheel drive, travel direction can be selected via joystick
- Service brake: Hydrostatic drive system acting on all 4 wheels (wear-free)
- Central service and parking brake in the drive train acting on all 4 wheels
- 100% differential lock, electric-hydraulically connectable on front and rear axle
- Tyres 11.5/80-15.3 AS ET80

Steering system

- Hydraulic articulated pendulum steering, 12° oscillating angle

Hydraulics

- 3rd control circuit front DN12
- Hydraulic oil cooler
- Floating position for lift and tilting cylinders
- Lock for steering valve

Driver's cabin

- "Low" overhead guard (height 2,313 mm) or "tall" (height 2,471 mm) with front and rear window, roll-over protective structure/FOPS tested
- Comfort seat with safety belt, fully suspended, weight, back and horizontal adjustment
- Joystick with direction control switch and integrated touch button for differential lock
- Adjustable steering column

Kinematics

- Z-kinematics

Other

- Working lights (2 front, 2 rear)
- Operating hour meter
- Battery isolator switch
- Fuel display
- Hydraulic quick-change system for attachments

## 3080LP

Wheel loader

### 3080LP Options

#### Motor

- Deutz TCD 2.9 L4 S5 (55,4 kW / 75 PS), Stage V
- Engine pre-heater/hydraulic oil pre-heater

#### Driver's cabin

- "Low" 2-door cabin, including heating and ventilation (height 2,313 mm)
- "Tall" 2-door cabin, including heating and ventilation (height 2,543 mm)
- "Tall" 1-door cabin, including heating and ventilation (height 2,532 mm)
- Air-cushioned comfort seat (fabric/artificial leather)
- Heated seat
- Radio
- Air-conditioning system

#### Lighting

- Lighting according to Road Traffic Regulations
- Rotating beacon
- MEGA working lights (2 front, 2 rear)
- LED working lights (2 front, 2 rear)

#### Drive system

- Speed increase to 30 km/h
- Axle PA1422
- Hand inching

#### Hydraulics

- Unpressurised reverse travel (front)
- Work hydraulics of large pump (73-103 l/min)
- High flow single-acting performance hydraulics (100-115 l/min), including unpressurised return line and additional hydraulic oil cooler
- 3rd control circuit proportional, including double notch via switch
- 4th control circuit additionally via 4-way valve
- Notch for joystick (single)
- Hydro connection in rear is dual-acting via reversing valve (l/min like 3rd control circuit in front)
- Dual-acting hydraulic connection in rear (51 l/min) (two couplings), including separate steering valve
- 2x hydraulic connection in rear (51 l/min) dual acting (four couplings), including separate steering valve

#### Electrical connections

- Front plug receptacle, 7-pole for lighting front attachments
- Plug receptacle in front, 3-pin (dual function)
- Plug receptacle for rear attachments, 7-pin
- Triple-pole rear plug receptacle

#### Other

- Reversing warning system
- Load-lowering valve
- Combination case with warning triangle and first-aid kit
- Tool box
- Technical Inspection Authority expert's report

- Fully automatic central lubrication unit
- Custommade paint finish
- Hand lever grease gun
- Load vibration dampening
- Self-recovery coupling

Please note: that product availability can vary from country to country. It is possible that information / products may not be available in your country. More detailed information on engine power can be found in the operator's manual; the stated power may vary due to specific operating conditions. Subject to alterations and errors excepted. Applicable also to illustrations.

Copyright © 2022 Weidemann GmbH.