

# 9080

## Wheel loader



**WEIDEMANN**  
*designed for work*



### 9080 Technical specifications

#### Engine data Standard

Manufacturer	Deutz
Engine type	TCD 3.6 S5
Cylinders	4
Engine performance	100 (136) kW (hp)
at rpm (max.)	2300 rpm
Cubic capacity	3621 cm <sup>3</sup>
Cooling system	Water/charge air
Emissions standard level	V
Exhaust after treatment	DOC/DPF/SCR

#### Engine data Option

Manufacturer	Deutz
Engine type	TCD 4.1 S5
Cylinders	4
Engine performance	115 (156) kW (hp)
at rpm (max.)	2300 rpm
Cubic capacity	4038 cm <sup>3</sup>
Cooling system	Water/charge air
Emissions standard level	V
Exhaust after treatment	DOC/DPF/SCR
<b>Electrical system</b>	
Operating voltage	12 V
Alternator (optional)	120 (150) A
<b>Weights</b>	
Operating weight (standard)	10722 kg
Tipping load with bucket - machine straight	5290 kg
Tipping load with bucket - machine articulated	4652 kg
Tipping load with pallet fork - machine straight	4624 kg
Tipping load with pallet fork - machine articulated	4071 kg
<b>Vehicle data</b>	
Axle	PA1900
Cab	Cab
Ground speed	0-20 (30/40) km/h
Speed stages	3
Fuel tank capacity	140 l
Hydraulic oil tank capacity	125 l
<b>Hydraulic system</b>	
Steering hydraulics - Oil flow (optional)	150 (180) l/min
Steering hydraulics - Operating pressure	250 bar
<b>Drive</b>	
Type of drive	Hydrostatic
Traction drive	Universal joint shaft

Tipping load calculation according to ISO 14397 (horizontal mast)

DPF = Diesel Particulate Filter

DOC = Diesel Oxidation Catalyst

SCR = Selective Catalytic Reduction

Vibrations (weighted average effective value)

**Hand-arm vibrations:** The hand-arm vibrations are no more than 2.5 m/s<sup>2</sup>

**Whole body vibrations:** This machine is equipped with an operator's seat that meets the requirements of EN ISO

7096:2000.

When the loader is used in accordance with the intended purpose, the whole body vibrations vary from below 0.5 m/s<sup>2</sup> up to a short-term maximum value.

It is recommended to use the values specified in the table when calculating the vibration values according to ISO/TR 25398:2006. At the same time the actual use conditions have to be taken into consideration.

Telehandler, like wheel loaders, are to be classified by operating weight.

Type of loader	Typical operating conditions	Average value			Standard deviation (s)		
		$1.4 \cdot a_{w,eqx}$ [m/s <sup>2</sup> ]	$1.4 \cdot a_{w,eqy}$ [m/s <sup>2</sup> ]	$a_{w,eqz}$ [m/s <sup>2</sup> ]	$1.4 \cdot s_x$ [m/s <sup>2</sup> ]	$1.4 \cdot s_y$ [m/s <sup>2</sup> ]	$s_z$ [m/s <sup>2</sup> ]
Compact wheel loader (operating weight < 4500 kg)	Load & carry (load and transport work)	0.94	0.86	0.65	0.27	0.29	0.13
Wheel loader (operating weight > 4500 kg)	Load & carry (load and transport work)	0.84	0.81	0.52	0.23	0.2	0.14
	Application in extraction (harsh application conditions)	1.27	0.97	0.81	0.47	0.31	0.47
	Transfer drive	0.76	0.91	0.49	0.33	0.35	0.17
	V-operation	0.99	0.84	0.54	0.29	0.32	0.14

# 9080

Wheel loader

## 9080 Dimensions

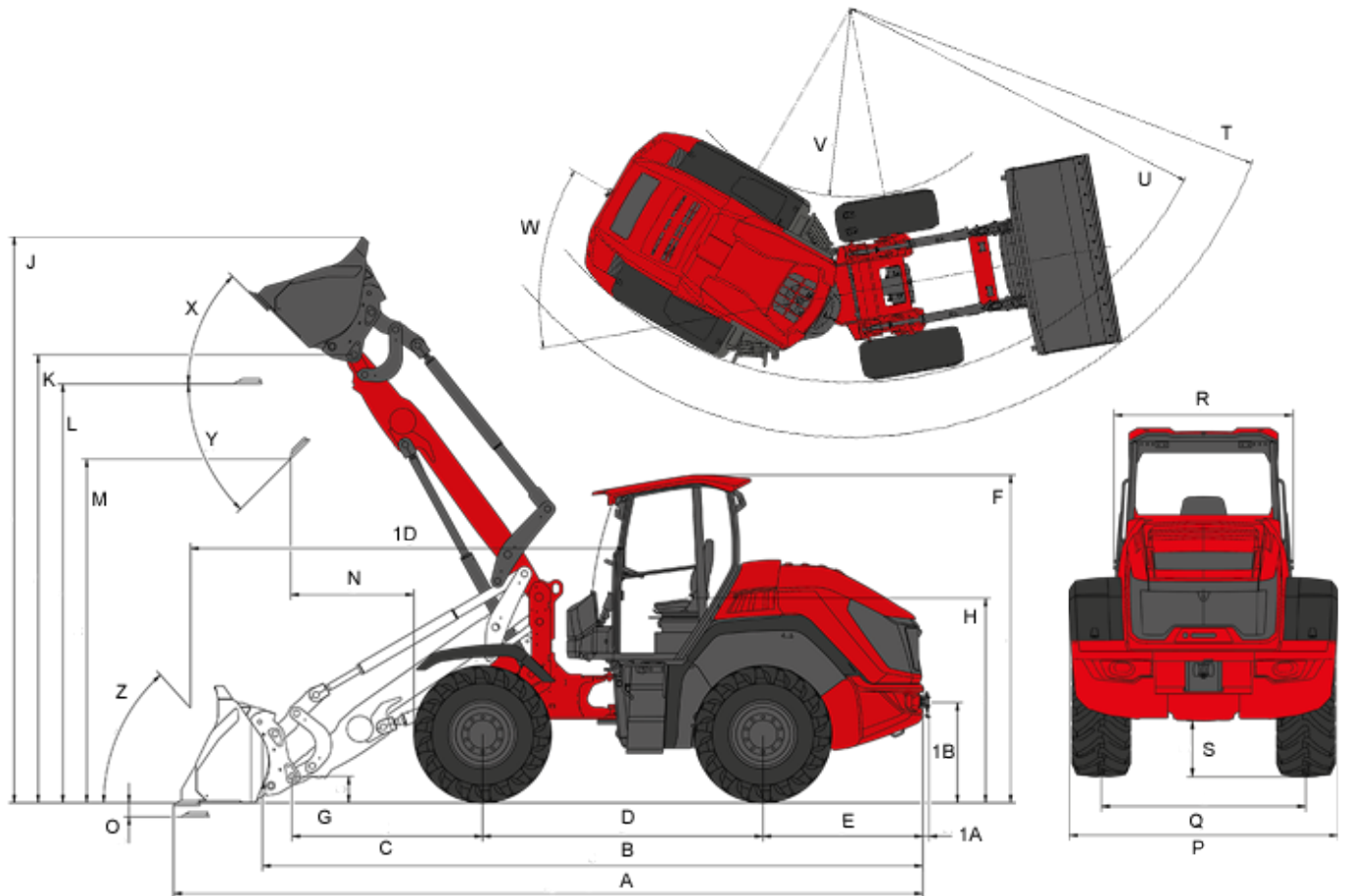

A	Total length	7,060 mm
B	Total length (without bucket)	6,270 mm
C	Axle middle to bucket pivot pin	1810 mm
D	Wheelbase	2,660 mm
E	Rear overhang	1,520 mm
F	Height to top of cabin	3,110 mm
H	Seat top height	1,940 mm
J	Total working height	5,250 mm
K	Height of bucket pivot (max.)	4,260 mm
L	Load-over height	3,980 mm
M	Dumping height	3,300 mm
N	Operating distance for M	1,140 mm
O	Digging depth	136 mm
P	Total width	2,390 mm
Q	Track width	1,820 mm
S	Ground clearance	502 mm
T	Maximum radius external	5,630 mm

U	Radius at the outer edge	4,900 mm
V	Inside turning radius	2,450 mm
W	Inclination angle	40 °
X	Rollback angle at max. lifting height	45 °
Y	Dumping angle (max.) (max.)	45 °
Z	Rollback angle (on the ground)	48 °

## 9080

Wheel loader

### 9080 Standard components

Engine

- Turbo diesel engine Deutz TCD 3.6 S5 (100 kW / 136 PS) | DOC/DPF/SCR | EU: Stage V

Steering system

- Hydraulic articulated steering with rear oscillating axle

Tyres

- 500 / 70 R24 Michelin XMCL ET 40

Drive / shaft

- Planetary axle PA1900
- Hydrostatic 4 wheel drive system through transfer gear and universal joint shaft, travel direction can be selected via joystick
- 100% differential lock front and rear axle
- Speed 20 km/h
- 3 speeds (7 km/h / 15 km/h / 20 km/h)
- Service brake: Multi-disc brake in the front axle acts on rear axle through universal joint shaft
- Parking brake: Electro-hydraulic, multi-disc spring-loaded brake in the front axle, acts on rear axle through universal joint shaft

Lighting

- Lighting according to Road Traffic Regulations (StVZO)
- Work lights, 4 front, 2 rear on the cabin roof

Cab

- 2-door comfort cabin, Roll Over Protection System/FOPS level 2
- Automatic air-conditioning system
- Sliding window in both doors; roof window with wiper
- Radio
- 7" colour display with all important machine information

Operator's seat

- Comfort seat with safety belt, fully suspended, weight, back and horizontal adjustment

Loader unit

- Load arm lift height 4260 mm
- Hydraulic quickhitch facility as per ISO 23727 (System Volvo TPV)
- P-kinematics
- 2 lift cylinders
- 2 tipping cylinder
- Automatic bucket return

Hydraulics

- Electric, pilot operated joystick with direction control switch and integrated touch button for differential lock
- 3rd control circuit in front electrically pilot-operated and proportional via joystick
- Oil volume adjustment via jog dial
- Pressure release of the hydraulic connections on the load arm
- Load sensing 150 l/min

Other

- Tool box
- Set of tools
- Reverse fan

StVZO - equipment

- Data confirmation (General Certification for Vehicles (Germany)) for self-propelled work machine\* (The licence plate illumination must also be ordered in conjunction with 30 or 40 km/h) \*Valid in: Germany, Luxembourg, Netherlands, Austria, Slovakian Republic, Czech Republic, Switzerland, Estonia, Latvia, Lithuania (for other countries please contact your local Weidemann distributor).

## 9080

Wheel loader

### 9080 Options

Operator's cab

- Protective grating of front window, removable (not approved for use on public roads!)
- Exterior mirror is heatable and electrically adjustable
- Window heating of rear window
- Vehicle heating, including engine pre-heater, programmable
- Document box
- Operating console support at B column
- Drive signal outlet, 7-pole, for salt spreader
- Carbon filter (cab air filter)

Operator's seat

- Fabric seat; air cushioned
- Fabric seat; air cushioned; heated

Lighting

- Work light at cab roof, 4 in front, 2 in rear, 2 in rear on the side
- LED work light at cab roof, 4 in front, 2 in rear, 2 in rear on the side
- Rotating beacon (yellow)

StVZO - equipment

- Licence plate illumination, including number plate bracket in front

Engine

- Turbo diesel engine Deutz TCD 4.1 S5 (115 kW / 156 PS) | DOC/DPF/SCR | EU: Stage V
- Engine pre-heating, fuel, hydraulic oil (230V)

Drive / shafts

- 30 km/h Power Drive 370 pushing power increase
- 40 km/h Power Drive 370
- Dual-line, pressure air-brake system
- Hand inching (low-speed control) and hand throttle

Tyres

- 540 / 70 R24 Michelin XMCL ET 0
- 600 / 55 R26.5 Alliance 331 ET 0
- 700 / 55 R26.5 Alliance 331 ET -50
- 17.5 R25 Michelin SNOWPLUS ET 50
- 17.5 R25 Michelin X-MINE ET50
- 540 / 70 R24 Michelin BIBLOAD ET 0
- Tyre blow-out protection

Loader unit

- Lifting arm damping
- Lifting arm damping for lowering brake valve (hose burst valves)
- Tipping cylinder lock
- Lowering brake valve (hose burst valve for lift and tipping cylinders)



#### Hydraulics in front

- Attachments for work platform (only ex works. Not retrofittable)
- Unpressurised reverse travel, front (including oil leakage pipe)
- Load sensing 180 l/min
- 4th control circuit, electrically proportionally controlled
- High Flow – double-acting performance hydraulics, 150 l/min
- High Flow – double-acting performance hydraulics, 180 l/min

#### Hydraulics in rear

- Unpressurised reverse travel, rear (including oil leakage pipe)
- Additional control circuit for tippers, rear (40 l/min), single-acting (one coupling)
- One hydraulic connection in rear (40 l/min), dual-acting (two couplings), including tipper connection
- Two hydraulic connections in rear (40 l/min), dual-acting (four couplings)

#### Bio-hydraulic oil

- Panolin HLP Synt46 (bio-hydraulic fluid (oil))

#### Electrical connections in front

- Outlet in front, 13-pole for dual function (operation: Via 2 touch buttons on joystick; 1st function momentary, 2nd function latching)
- Outlet in front, 13-pole for dual function (operation: Via 2 touch buttons on joystick; 1st function latching, 2nd function momentary)
- Outlet in front, 13-pole for dual function (operation: Via 2 touch buttons on joystick; 1st function momentary, 2nd function momentary)
- Outlet in front, 13-pole for dual function (operation: Via 2 touch buttons on joystick; 1st function latching, 2nd function latching)

#### Electrical connections in rear

- Outlet in rear, 7-pole for lighting rear attachments
- Triple-pole outlet in rear

#### Safety options

- Reversing alarm (audible)
- Red / white warning stripes (according to DIN 30710)
- Industrial protection package
- Drive interlock (operation via coded ignition switch key)
- Triangular labelling board

#### Other

- Combination bag (warning triangle / first aid kit)
- Fully automatic central lubrication unit
- Fully automatic central lubrication unit (aggressive media: Hardware and steel connections)
- Protective measures for use in aggressive materials (salt and fertilizer use)

#### Custom-made paint finish

- Single colour RAL custom-made paint finish - instead of Weidemann red

#### Coupling and retrieval devices

- Automatic, height-adjustable ball hitch
- Pillow block for ball hitches
- Automatic ball hitch for trailer, height adjustable for pillow block
- K50 ball hitch for trailer, height adjustable for pillow block
- K80 ball hitch for trailer, height adjustable for pillow block

- Piton-Fix ball hitch, height adjustable for pillow block
- CUNA D3 ball hitch, height adjustable for pillow block
- Autohitch ball hitch incl. tipper connection
- Autohitch ball hitch (incl. hydr. control) and double-acting hydraulic connection in rear including tipper connection
- Hydraulic trailer brake valve

Official approval for road use

- EC Tractor approval (different in every country. For more information please contact your local Weidemann distributor)

Please note: that product availability can vary from country to country. It is possible that information / products may not be available in your country. More detailed information on engine power can be found in the operator's manual; the stated power may vary due to specific operating conditions. Subject to alterations and errors excepted. Applicable also to illustrations.

Copyright © 2022 Weidemann GmbH.