

9580T

Telescopic wheel loader



WEIDEMANN
designed for work



9580T Technical specifications

Engine data Standard

Manufacturer	Deutz
Engine type	TCD 3.6 S5
Cylinders	4
Engine performance	100 (136) kW (hp)
at rpm (max.)	2300 rpm
Cubic capacity	3621 cm ³
Cooling system	Water/charge air
Emissions standard level	V
Exhaust after treatment	DOC/DPF/SCR

Engine data Option

Manufacturer	Deutz
Engine type	TCD 4.1 S5
Cylinders	4
Engine performance	115 (156) kW (hp)
at rpm (max.)	2300 rpm
Cubic capacity	4038 cm ³
Cooling system	Water/charge air
Emissions standard level	V
Exhaust after treatment	DOC/DPF/SCR
Electrical system	
Operating voltage	12 V
Alternator (optional)	120 (150) A
Weights	
Operating weight (standard)	11210 kg
Tipping load with bucket - machine straight	6594 (3495*) kg
Tipping load with bucket - machine articulated	5871 (3112*) kg
Tipping load with pallet fork - machine straight	5775 (3265*) kg
Tipping load with pallet fork - machine articulated	5142 (2907*) kg
Vehicle data	
Axle	PA1900
Cab	Cab
Ground speed	0-20 (30/40) km/h
Speed stages	3
Fuel tank capacity	140 l
Hydraulic oil tank capacity	125 l
Hydraulic system	
External services - Operating pressure	480 bar
Steering hydraulics - Oil flow (optional)	150 (180) l/min
Steering hydraulics - Operating pressure	250 bar
Drive	
Type of drive	Hydrostatic
Traction drive	Universal joint shaft
Noise values	
Average sound power level LwA	100.7 dB(A)
Guaranteed sound power level LwA	102 dB(A)
Specified sound pressure level LpA	70 dB(A)

*Tipping load values when extended

Tipping load calculation according to ISO 14397 (lift frame horizontal)

DPF = Diesel Particulate Filter

DOC = Diesel Oxidation Catalyst

Vibrations (weighted average effective value)

Hand-arm vibrations: The hand-arm vibrations are no more than 2.5 m/s²

Whole-body vibrations: This machine is equipped with an operator's seat that meets the requirements of EN ISO 7096:2000.

When the loader is used in accordance with the intended purpose, the whole body vibrations vary from below 0.5 m/s² up to a short-term maximum value.

It is recommended to use the values specified in the table when calculating the vibration values according to ISO/TR 25398:2006. At the same time, the actual use conditions have to be taken into consideration.

Telehandlers, like wheel loaders, are to be classified by operating weight.

Type of loader	Typical operating conditions	Mean value			Standard deviation (s)		
		1.4*a _{w,eqx} [m/s ²]	1.4*a _{w,eqy} [m/s ²]	a _{w,eqz} [m/s ²]	1.4*s _x [m/s ²]	1.4*s _y [m/s ²]	s _z [m/s ²]
Compact wheel loader (operating weight < 4,500 kg)	Load & carry (load and transport work)	0.94	0.86	0.65	0.27	0.29	0.13
Wheel loader (operating weight > 4,500 kg)	Load & carry (load and transport work)	0.84	0.81	0.52	0.23	0.2	0.14
	Application in extraction (harsh application conditions)	1.27	0.97	0.81	0.47	0.31	0.47
	Delivery drive	0.76	0.91	0.49	0.33	0.35	0.17
	V-operation	0.99	0.84	0.54	0.29	0.32	0.14

9580T

Telescopic wheel loader

9580T Dimensions

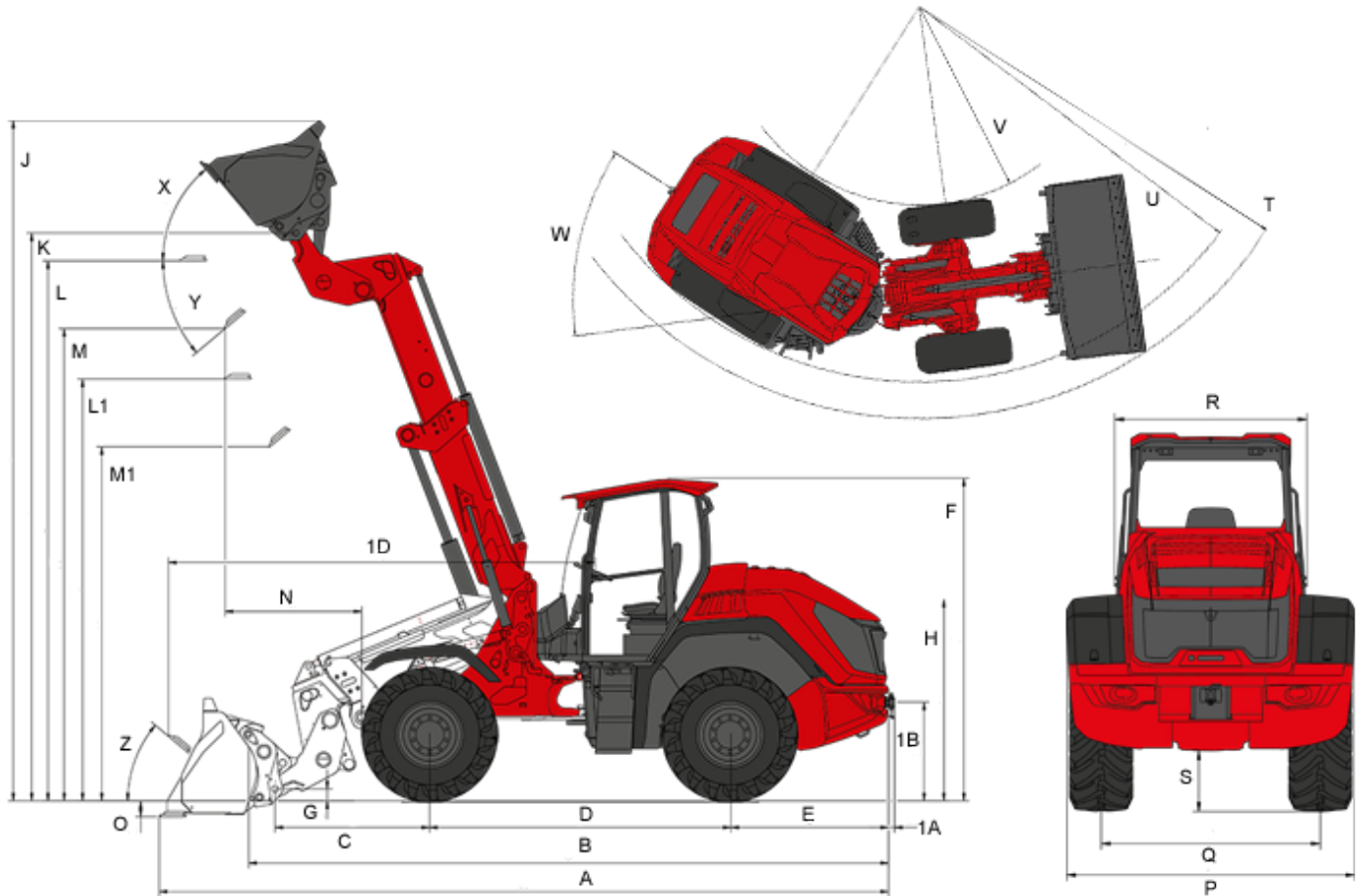

A	Total length	6,980 mm
B	Total length (without bucket)	6,090 mm
C	Axle middle to bucket pivot pin	1440 mm
D	Wheelbase	2,900 mm
E	Rear overhang	1,520 mm
F	Height to top of cabin	3,110 mm
H	Seat top height	1,940 mm
J	Total working height	6,500 mm
K	Height of bucket pivot (max.)	5,480 mm
L	Load-over height	5,210 mm
M	Dumping height	4,580 mm
N	Operating distance for M	1,300 mm
O	Digging depth	130 mm
P	Total width	2,390 mm
Q	Track width	1,820 mm
S	Ground clearance	502 mm
T	Maximum radius external	5,770 mm

U	Radius at the outer edge	4,900 mm
V	Inside turning radius	2,450 mm
W	Inclination angle	40 °
X	Rollback angle at max. lifting height	50 °
Y	Dumping angle (max.)	40 °
Z	Rollback angle (on the ground)	40 °

9580T

Telescopic wheel loader

9580T Standard components

Engine

- Turbo diesel engine Deutz TCD 3.6 S5 (100 kW / 136 hp) | DOC/DPF/SCR , EU: Stage V

Steering system

- Hydraulic articulated steering with rear pendulum axle

Tires

- 500 / 70 R24 Michelin XMCL ET 40

Drive / shaft

- Planetary axle PA1900
- Hydrostatic all-wheel drive system through PTO gear and driveshaft, travel direction can be selected via joystick
- 100% differential lock front and rear axle
- Speed 20 km/h
- 3 speeds (7 km/h / 15 km/h / 20 km/h)
- Service brake: Multi-disc brake in the front axle acts on rear axle through universal joint shaft
- Parking brake: Electro-hydraulic, multi-disc spring-loaded brake in the front axle, acts on rear axle through universal joint shaft

Lighting

- Lighting according to Road Traffic Regulations
- Work lights, 4 front, 2 rear on the cabin roof

Cab

- 2-door comfort cabin, Roll Over Protection System/FOPS level 2
- Automatic air-conditioning system
- Sliding window in both doors; roof window with wiper
- Radio
- 7" colour display with all important machine information

Operator's seat

- Comfort seat with safety belt, fully suspended, weight, back and horizontal adjustment

Loader unit

- Telescopic arm lifting height 5480 mm
- Hydraulic quickhitch facility as per ISO 23727 (System Volvo TPV)
- Z-kinematics
- 1 lift cylinders
- 1 tipping cylinder
- Automatic bucket return
- Lowering brake valve (hose burst valve for lift and tipping cylinders)

Hydraulics

- Electric, pilot operated joystick with direction control switch and integrated touch button for differential lock
- 3rd control circuit in front electrically pilot-operated and proportional via joystick
- Oil volume adjustment via jog dial
- Pressure release of the hydraulic connections on the load arm
- Load sensing 150 l/min

- Unpressurised return line, front (including oil leakage pipe)

Other

- Tool box
- Set of tools
- Reverse fan
- Plug receptacle in front, 13-pole for dual function

STVZO - equipment

- Data confirmation (General Certification for Vehicles (Germany)) for self-propelled work machine* (The licence plate illumination must also be ordered in conjunction with 30 or 40 km/h) *Valid in: Germany, Luxembourg, Netherlands, Austria, Slovakian Republic, Czech Republic, Switzerland, Estonia, Latvia, Lithuania (for other countries please contact your local Weidemann distributor).

9580T

Telescopic wheel loader

9580T Options

Driver's cab

- Exterior mirror is heatable and electrically adjustable
- Window heating of rear window
- Vehicle heating, including engine pre-heater, programmable
- Document box
- Operating console support at B column
- Drive signal outlet, 7-pole, for salt spreader
- Carbon filter (cab air filter)

Operator's seat

- Fabric seat; air cushioned
- Fabric seat; air cushioned; heated

Lighting

- Work light at cab roof, 4 in front, 2 in rear, 2 in rear on the side
- LED work light at cab roof, 4 in front, 2 in rear, 2 in rear on the side
- Work lights LED on telescopic arm, 2 in front
- Rotating beacon (yellow)
- Rotating LED beacon (yellow)

STVZO - equipment

- Licence plate illumination, including number plate bracket in front

Engine

- Turbo diesel engine Deutz TCD 4.1 S5 (115 kW / 156 hp) | DOC/DPF/SCR | EU: Stage V
- Engine pre-heating, fuel, hydraulic oil (230V)

Drive / shafts

- 30 km/h Power Drive 370 pushing power increase
- 40 km/h Power Drive 370
- Dual-line, pressure air-brake system
- Hand inching (low-speed control) and hand throttle

Tyres

- 540 / 70 R24 Michelin XMCL ET 0
- 600 / 55 R26.5 Alliance 331 ET 0
- 700 / 55 R26.5 Alliance 331 ET -50
- 17.5 R25 Michelin SNOWPLUS ET 50
- 540 / 70 R24 Michelin BIBLOAD ET 0
- Tyre blow-out protection

Loader unit

- Load arm damping

Hydraulics in front

- Attachments for work platform (only ex works. Not retrofittable)
- 3rd control circuit load-sensing 180 l/min, work hydraulics
- High Flow - double-acting performance hydraulics, 150 l/min

- High Flow – double-acting performance hydraulics, 180 l/min
- Reversing valve in front on 3rd control circuit (3rd control circuit with 4 connections)

Hydraulics in rear

- Unpressurised reverse travel, rear (including oil leakage pipe)
- Additional control circuit for tippers, rear (40 l/min), single-acting (one coupling)
- One hydraulic connection in rear (40 l/min), dual-acting (two couplings), including tipper connection
- Two hydraulic connections in rear (40 l/min), dual-acting (four couplings)

Bio-hydraulic oil

- Panolin HLP Synt46 (bio-hydraulic fluid (oil))

Electrical connections in front

- Outlet in front, 13-pole for dual function (operation: Via 2 touch buttons on joystick; 1st function latching, 2nd function momentary)
- Outlet in front, 13-pole for dual function (operation: Via 2 touch buttons on joystick; 1st function momentary, 2nd function momentary)
- Outlet in front, 13-pole for dual function (operation: Via 2 touch buttons on joystick; 1st function latching, 2nd function latching)

Electrical connections in rear

- Outlet in rear, 7-pole for lighting rear attachments
- Triple-pole outlet in rear

Safety options

- Reversing alarm (audible)
- Red / white warning stripes (according to DIN 30710)
- Industrial protection package
- Drive interlock (operation via coded ignition switch key)
- Triangular labelling board

Other

- Combination bag (warning triangle / first aid kit)
- Fully automatic central lubrication unit
- Fully automatic central lubrication unit (aggressive media: Hardware and steel connections)
- Protective measures for use in aggressive materials (salt and fertilizer use)

Custom-made paint finish

- Single colour RAL custom-made paint finish - instead of Weidemann red

Coupling and retrieval devices

- Automatic, height-adjustable ball hitch
- Pillow block for ball hitches
- Automatic ball hitch for trailer, height adjustable for pillow block
- K50 ball hitch for trailer, height adjustable for pillow block
- Piton-Fix ball hitch, height adjustable for pillow block
- CUNA D3 ball hitch, height adjustable for pillow block
- Autohitch ball hitch incl. tipper connection
- Autohitch ball hitch (incl. hydr. control) and double-acting hydraulic connection in rear including tipper connection
- Hydraulic trailer brake valve

Official approval for road use

- EC Tractor approval (different in every country. For more information please contact your local Weidemann distributor)

Please note: that product availability can vary from country to country. It is possible that information / products may not be available in your country. More detailed information on engine power can be found in the operator's manual; the stated power may vary due to specific operating conditions. Subject to alterations and errors excepted. Applicable also to illustrations.
Copyright © 2022 Weidemann GmbH.