



REAR MOUNT ROUND ROTARY CUTTERS

BE-RCRXXXG



OPERATIONS & PARTS MANUAL

FOR MODELS:

- BE-RCR350G
- BE-RCR400G
- BE-RCR500G
- BE-RCR600G

PURCHASE DATE	MODEL NO.	SERIAL NUMBER
DEALER		

TABLE OF CONTENTS

3	GENERAL INFORMATION & SAFETY
5	PREPARATION
8	OPERATION
9	MAINTENANCE
11	TROUBLESHOOTING
13	EXPLODED VIEW & PARTS LIST

TO THE CUSTOMER

This manual contains valuable information about your new mower. It has been carefully prepared to give you helpful suggestions for operating, adjusting, and servicing.

Keep this manual in a convenient place for quick and easy reference. Study it carefully, only by proper care and operation can you expect to receive the service and long life designed and built into this mower.

It is the owner's and/or operator's responsibility to...

- Read and understand the information contained in this manual.
- Operate, lubricate, assemble and maintain the equipment in accordance with all instructions and safety procedures in this manual.
- Inspect the equipment and replace or repair any parts that are damaged or worn which could cause damage, wear to other parts, or cause a safety hazard.

SAFETY

READ AND FOLLOW THE INSTRUCTIONS IN THIS MANUAL, ESPECIALLY IN THE SAFETY SECTION. FAILURE TO DO SO COULD RESULT IN SERIOUS INJURY OR DEATH.

TAKE NOTE! THIS SAFETY ALERT SYMBOL IS FOUND THROUGHOUT THIS MANUAL. THIS SYMBOL IS USED TO CALL YOUR ATTENTION TO INSTRUCTIONS CONCERNING YOUR PERSONAL SAFETY AND THE SAFETY OF OTHERS.



This symbol means attention. Be on the alert! Your safety is involved!

CRITICAL TERMS:

The critical terms DANGER, WARNING and CAUTION are used with the safety messages in this manual and with each safety decal. They are defined as follows:

⚠ DANGER:

Indicates an immediate hazardous situation that, if not avoided, could result in serious injury or death. This Critical Term is to be limited to the most extreme situations, typically for machine components that, for functional purposes, cannot be guarded.

⚠ WARNING:

Indicates a potentially hazardous situation that, if not avoided, could result in serious injury or death, and includes hazards that are exposed when guards are removed. It may also be used to alert against unsafe practices.

⚠ CAUTION:

Indicates a potentially hazardous situation that, if not avoided, may result in minor or moderate injury. It also may be used to alert against unsafe practices.

⚠ EQUIPMENT SAFETY GUIDELINES

Safety of the operator and bystanders is one of the main concerns in designing and developing a mower. However, every year accidents occur which could have been avoided by a few moments of thought and a more careful approach to handling equipment. You, the operator, can avoid many accidents by observing the following precautions and insist those working with or for you adhere to them.

In order to provide a better view, certain illustrations in this manual may show an assembly with a safety guard removed. However, equipment should never be operated in this condition. Keep all guards in place. If guard removal becomes necessary for repairs, reinstall the guards prior to use.

Replace any safety decal that is not legible or is missing. The locations of such safety decals are indicated in this manual.

Never operate this equipment while using alcoholic beverages or drugs that can hinder alertness or coordination. Consult your doctor about operating this machine while taking prescription medications.

Under no circumstances should children under the age of 18 be allowed to work with or around this equipment. Do not allow anyone to operate or assemble this equipment until they have read this manual and have developed a thorough understanding of the safety precautions and operation. Review safety instructions with all users annually.

This equipment is dangerous to children and anyone unfamiliar with its operation. The operator should be a responsible, properly qualified and physically able person familiar with farm machinery and competent in this equipment's operation.

Never exceed the limits of a piece of machinery. If its ability to do a job, or to do so safely, is in question- DON'T TRY IT.

Use a tractor equipped with a Roll Over Protective System and seat belt. (ROPS)

Do not modify the equipment in any way. Unauthorized modifications could result in serious injury or death and may impair the function and shorten the life of the equipment.

In addition to the design of this implement, safety decals and safety equipment, accident prevention is dependent upon the awareness, common sense, forethoughts, and proper training of everyone involved in the operation, transport, maintenance, and storage of the machine. Also refer to safety messages and operating instructions in each of the appropriate sections of the tractor manual. Pay close attention to the safety decals affixed to the tractor and Rough-Cut Mower.

BEFORE PUTTING ROUGH CUTTING MOWER INTO SERVICE

IMPORTANT INSTRUCTIONS PRIOR TO OPERATING

MOWER SHIPPED WITHOUT OIL IN GEAR BOX AND WITHOUT GREASE IN GREASE FITTINGS. UNIT MUST BE SERVICED BEFORE USING.

Fill Gearbox using Multi-Purpose Gear Oil.

For all Grease Fittings use a high-temp/multi-purpose grease.

STEP 1 Place Rough Cutting Mower so that the deck is secure and level.

STEP 2 Remove the plug located at top of gearbox and 1/8" pipe plug (located at lower with lower 1/3" of gearbox.)

STEP 3 Fill gearbox using multi-purpose gear oil through top 1/2" fill hole until gear oil is level with lower 1/8" hole.

STEP 4 Replace both the 1/2" pipe plug (located at top of gear box) and 1/8" pipe plug (located at lower 1/3 of gear box) and clean off any excess oil.

STEP 5 Grease the following zerks:

*Both U-Joints on the PTO shaft

STEP 6 Inspect all guards to insure they are in good working order. If not replace before using.

STEP 7 Check all bolts and nuts to insure they are tight and secure.

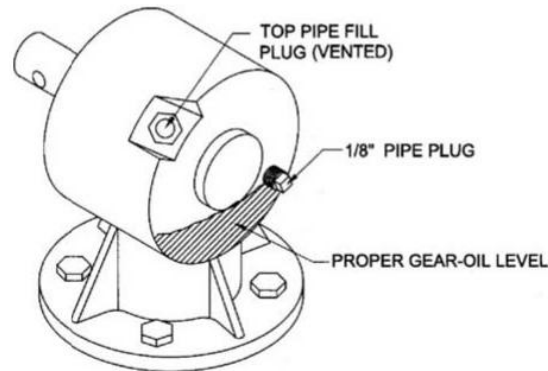

⚠ CAUTION:

DO NOT overfill gearbox. This could cause damage to oil seals and can cause permanent damage to the gearbox. This issue will not be covered under warranty.

⚠ PREPARATION

Never operate the tractor and mower until you have read and completely understand this manual, the Tractor Operator's Manual, and each of the messages found on the safety decals on the tractor and mower.

Personal protection equipment including hardhat, safety glasses, safety shoes, and gloves are recommended during assembly, installation, operation, adjustment, maintenance, repairing, removal, or moving the implement. Do not wear loose fitting clothing or jewelry and be sure to contain long hair around equipment.

PROLONGED EXPOSURE TO LOUD NOISE MAY CAUSE PERMANENT HEARING LOSS! Tractors with or without mowers attached can often create enough noise to cause permanent hearing loss. We recommend that you use hearing protection if the noise in the operator's position exceeds 80db. Long-term exposure to noise levels over 80db can cause severe hearing loss. Long-term exposure to noise levels over 90db adjacent to the operator may cause permanent total hearing loss.

NOTE: Hearing loss from loud noises (from tractors, radios, and other sources close to the ear) is cumulative over a lifetime, with no chance of natural recovery.

Always wear your seat belt. Serious injury or even death could result from falling off the tractor particularly during a rollover when the operator could be trapped under the ROPS or the tractor.

Clear area to be cut of stones, branches and other debris that might be thrown causing injury or damage.

Operate only in daylight or good artificial light.

Ensure mower is properly mounted, adjusted and in good operating condition.

Ensure that all safety guards and safety decals are properly installed and in good condition.

⚠ STARTING AND STOPPING SAFETY

Check the tractor master guard over the PTO shaft. Make sure it is in good condition and fastened securely to the tractor. Purchase a new guard if old guard is damaged or missing.

All tractors that are not equipped with a "live" Power Take Off (PTO) need to be equipped with an over-running PTO clutch. These are available through most farm equipment stores.

NOTE: The addition of an over-running PTO clutch may change the length of the PTO driveline required. Pay extra attention to the instructions on the PTO driveline Installation. Be sure that the driveline system guarding is sufficient.

Mower operating power is supplied from tractor PTO. Refer to your tractor manual for PTO engagement and disengagement instructions. Know how to stop the tractor and mower quickly in case of an emergency.

The engine RPM should always be at idle speed when engaging the PTO. Once engaged and you are ready to start cutting, increase the PTO speed to approximately 540 RPM and maintain throughout the cutting operation.

The use of this equipment is susceptible to certain hazards that cannot be protected against by mechanical means or product design. All operators of this equipment must read and understand this entire manual, paying particular attention to safety and operating instructions, prior to using.

Most accidents occur because of neglect or carelessness. Keep all assistants and bystanders several hundred feet from the operating Rough Cutting Mower.

When machine is operated in populated areas where thrown objects could injure persons or property, operation must be stopped if anyone comes within a few hundred feet.

The majority of the accidents involve entanglement on the driveline, injury of bystanders by the objects thrown by the rotating blades, and operators being knocked are most likely to occur with machines that are then being run over by the mower. Accidents are most likely to occur with machines that are loaned or rented to someone who has not read the owner's manual and is not familiar with a Rough Cutting Mower.

The Rough Cutting Mower is designed for use on tractors with a 540-RPM power take off.

Install and secure all guards and shields before starting or operating. The discharge chute, flaps, driveline guards and tractor guards should be used and maintained in good working condition. They should be inspected carefully daily for missing or broken cables, shields, and guards. Worn items must be replaced at once to reduce the possibility of injury

Disengage Power Take Off (PTO) and place tractor transmission in neutral before attempting to start engine.

Many varied objects, such as wire, cable, rope can become entangled in the working parts of the mower. These objects could then swing outside the housing at a greater velocity than the blades. Such a occurrence is extremely hazardous. Inspect the cutting area for such objects before mowing. Remove any objects from the site.

Never allow the cutting blade to contact objects. Cut higher at first, allowing Rough Cutting Mower to clear such hidden objects. Never assume an area is clear. Always Check!

Always stop the tractor, disengage PTO, allow cutter blades to come to a complete stop, lower implement to the ground, set brake, shut off the tractor engine and remove the ignition key before dismounting tractor. Never leave equipment unattended while the tractor is running. Never place hands or feet under mower. Stay clear of all moving parts.

Do not reach or place any part of your body under the equipment until it is blocked securely.

Do not allow riders on the Rough Cutting Mower or tractor at any time. There is no safe place for riders.

Do not operate unless all personnel, livestock, and pets are several hundred feet away to prevent injury by thrown objects. Never direct the discharge chute toward anyone.

Never operate tractor and Rough Cutting Mower under trees with low hanging limbs. Operators can be knocked off the tractor and then run over by the rotating blades.

The rotating parts of this machine have been designed and tested for rugged use. However, they could fail upon impact with heavy, solid objects such as steel guardrails and concrete abutments. To reduce the possibility of property damage, serious injury, or even death never allow the cutting blades to come in contact such objects.

Stop mower and tractor immediately upon striking an obstruction. Turn engine off, remove key, then inspect and repair any damage before resuming operation.

Stay alert for uneven terrain, holes, roots and other hidden hazards. Keep away from drop-offs and hazards that could cause rollover. Use extreme care and maintain minimum ground speed when transporting or operating on hillsides, over rough ground and when operating close to ditches or fences. Be careful and slow down when turning sharp corners and changing direction on slopes. Do not start or stop suddenly on slopes and avoid operating on steep slopes. In extremely uneven terrain, rear wheels weights, front tractor weights, and/or tire ballast should be used to improve stability.

Drive Rough Cutting Mower diagonally over sharp dips and avoid sharp drops to prevent tractor and Rough Cutting Mower from "hanging up". Always cut downward on slopes, never cut across the face. Always check tractor manual for proper use on slopes. Practice will improve your skills in maneuvering on rough terrain.

A minimum 20% of the tractor and equipment weight must be on tractor front wheels. Without this weight, the tractor could tip over, causing personal injury or death. The weight may be attained with a front-end loader, front-end loader, front wheel weights, ballast in the tires or front tractor weights. When attaining a minimum 20% of the tractor and equipment weight on the front wheels, you must not exceed the ROPS weight certification. Weigh the tractor and equipment. Do not guess or estimate!

▲ TRANSPORT SAFETY

Always observe state and local laws governing highway safety and the travel of farm machinery on public roads.

The use of flashing amber lights is acceptable in most locations. However, some locations prohibit use. Local laws should be checked for all lighting and marking requirements.

When driving the tractor and equipment on roads or highways use flashing amber warning lights and a slow-moving vehicle (SMV) identification emblem. Do not exceed 20 mph. Reduce speed on rough roads and surfaces.

Plan your route to avoid heavy traffic.

Always install transport locks, pins or brackets before transporting.

Do not drink and drive.

Be a safe and courteous driver. Always yield to oncoming traffic in all circumstances, including narrow bridges, intersections, etc. Watch for traffic when crossing or operating in close proximity to roadways.

Turn curves and go up and down hills only at a low speed at a gradual steering angle. Make certain that a least 20% of the tractor's weight is on the front wheels to maintain safe control. Slow down on rough and/or uneven surfaces. Always check tractor manual for proper use on slopes.

Use extreme care and maintain minimum ground speed when operating close to ditches and/or fences. Be careful when turning sharp corners.

Never allow riders on either tractor or mower.

ATTACHING TO TRACTOR

▲ WARNING

Never stand between tractor and Rough Cutting Mower while backing the tractor up to the hitch

STEP 1 Attach to tractor's three point hitch as described in the Tractor's Operator's Manual.

STEP 2 Apply any multi-purpose grease to the outside of the male (inner) PTO shaft section. Assemble PTO shaft and install on Rough Cutting Mower and tractor.

▲ WARNING

Failure to install the retaining clip on gearbox input shaft would allow the driveline to swing freely if the bolt is sheared causing possible injury or death.

STEP 3 Pull shaft on tractor side of PTO shaft yoke to be sure it has locked in place. Make certain PTO shaft guards are in place and good working condition.

STEP 4 The PTO shaft guard is a non-rotating design and must be secured prior to equipment use.

OPERATING INSTRUCTIONS

This mower was designed to CUT PASTURE GRASS AND ROUGH AREAS UP TO 1" IN DIAMETER. Use of your Rough Cutting Mower to cut any material larger than 1" in diameter may damage the mower and void your warranty.

PRE-OPERATIONAL ADJUSTMENTS

Set tractor's lift control stop at a position that will prevent the PTO shaft from coming in contact with the front edge of the mower when it is at full lift. Consult your tractor manual for instructions.

OPERATION

CUTTING HEIGHT ADJUSTMENT

To prevent blades from striking the ground, your rough cut mower should be set to the highest position that will give you the desired cutting height. By setting your mower up this way, you reduce blade wear and stress on the mower. Mowing at regular intervals will produce far better results than periodic mowing.

Raise rough cut mower off the ground with the tractor and **SECURELY BLOCK IN POSITION**. Remove M10 round head carriage bolt from adjusting bracket.

Move the A Frame up or down to desired cutting height. Reinstall M10 round head carriage bolt and tighten to secure in position.

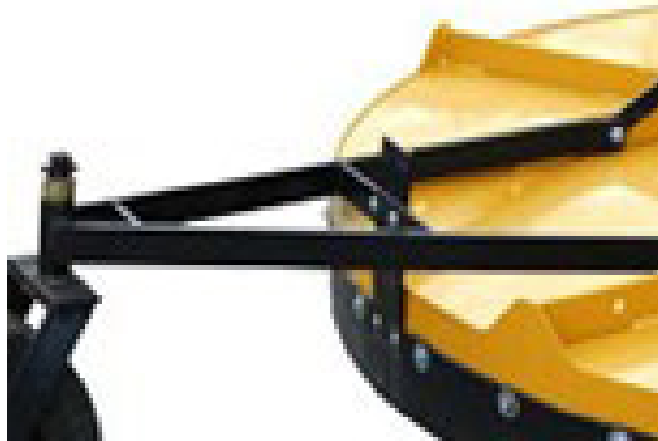

Note: For best results in heavier cutting conditions adjust the deck so the rear of the mower is approximately 2" higher than the front. This method requires less horsepower and ground speeds of approximately 3-5mph. If finer shredding results are desired, adjust the deck to level or slightly lower in the rear. This method will keep foliage under the deck longer resulting in finer pieces. The down side of this method is if it takes a lot more horsepower and very slow ground speed. This method is not recommended unless a PTO speed of 540RPM can be maintained.

ROUGH CUT MOWER OPERATION

STEP 1

Before each use, perform the maintenance described in maintenance section.

STEP 2

Read, understand, and follow the information on safety, preparation, starting and stopping safety, operational safety and transport safety warning sections of this manual.

STEP 3

With tractor running, lower rough-cut mower into working position.

STEP 4

With the tractor at idle RPM, engage PTO and slowly advance throttle to approximately 540 PTO RPM.

NOTE: The rough-cut mower was designed to run at 540 PTO RPM.

STEP 5

Select a low tractor gear and begin to mow. Tractor ground speed is to be controlled by gear selection only and not engine speed. Tractor PTO speed should allow rough cut mower to maintain 540 PTO RPM and thus maximum blade tip speed.

NOTE: Do not allow the tractor engine or rough-cut mower to bog down or stall. This causes unnecessary wear and tear on the mower and tractor. If this continues to occur, reduce ground speed and/or raise the cutting height of the rough-cut mower.

NEVER ATTEMPT TO CLEAN OUT A CLOGGED DISCHARGE CHUTE UNTIL THE MOWER BLADES HAVE COMPLETELY STOPPED AND THE TRACTOR HAS BEEN SHUT OFF.

STEP 6

After each use, clean all debris from the top and bottom of the rough-cut mower. Replace any missing or illegible safety decals. Inspect for any damaged or worn parts and replace before next use. Store the rough-cut mower in a dry environment.

MAINTENANCE

1. Periodically check and maintain proper gear oil level.
2. Approximately every 8 hours, grease spindles, roller axle, wheel forks, wheel axles, PTO shaft universal joints, and PTO telescoping surface.
NOTE: Use a high-temp / multi-purpose grease.
3. Before each use check to make sure all safety features are installed and working properly.
4. Keep blades sharp and balanced at all times. When replacing the blades, replace all blades and blade bolts and the same time.
5. Periodically check all nuts, bolts, and belt to insure they are tight and secure.

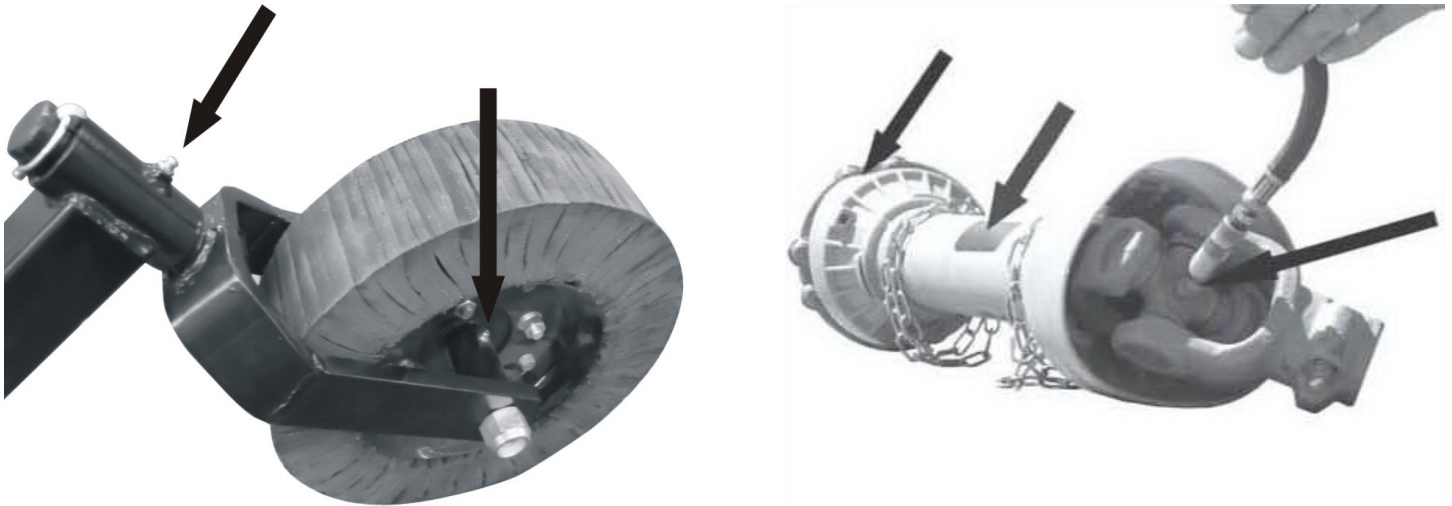

Arrows indicate grease points.

⚠ MAINTENANCE SAFETY

Good maintenance is your responsibility. Poor maintenance is an invitation on trouble.

Follow good shop practices.

Keep service area clean and dry.

Be sure electrical outlets and tools are properly grounded.

Use adequate light for the job at hand.

Make sure there is ample ventilation. Never operate the tractor engine in a closed building. The exhaust fumes may cause asphyxiation.

Before working on this machine, disengage the PTO, be certain all moving parts on attachments have come to a complete stop, shut off the engine, set the brakes, and remove the ignition keys before attempting to perform maintenance.

Never work under equipment unless it is blocked securely.

Always use personal protection devices such as eye, hand and hearing protectors when performing any service or maintenance.

Frequently tighten all bolts, nuts, screws and check that all cotter pins are properly installed to make certain unit is safe to operate.

When completing maintenance or service, make sure all safety guards and devices are installed before using the Rough Cutting Mower.

After servicing, be sure all tools, parts and service equipment are removed from the Rough Cutting Mower.

Do not allow debris, grease or oil to build up on any deck or platform.

Where replacement parts are necessary for periodic maintenance and servicing, factory replacement parts must be used to restore your equipment to original specifications.

The manufacturer and/or distributor will not be responsible for injuries damages caused by use of unapproved parts and/or accessories.

A first aid kit should be kept readily accessible while performing maintenance on this equipment.

⚠ STORAGE SAFETY

Following use, or when unhooking the mower, disengage the PTO, stop the tractor, set the brakes, shut off the engine and remove the ignition keys.

Store the unit in an area away from human activity.

Do not park equipment where it can be exposed to direct contact with livestock for long periods of time. Damage to mower and/or livestock injury could result.

Make sure all parked machines are on a hard, level surface and that all safety devices engaged.

ROTARY CUTTER SAFETY SIGNS

⚠ DANGER



**ROTATING DRIVELINE HAZARD
KEEP AWAY**

To prevent serious injury or death from rotating driveline:

- Keep all guards in place when operating.
- Operate only at 540 RPM
- Keep hands, feet, clothing and hair away from moving parts.
- Do not operate without driveline securely attached at both ends.
- Do not operate without driveline shields that turn freely on driveline.

⚠ DANGER



ROTATING BLADES-KEEP AWAY

To prevent serious injury or death when the engine is running and the blades are rotating:

- Never allow riders, especially children, on tractor or mower.
- Do not operate with bystanders in mowing area.
- Do not operate with deflector/guards removed.
- Do not place hands or feet under deck.
- Do not stand on or near implement at any time.
- Do not stand between tractor and implements.
- Operate only with tractor equipped ROPS and seatbelts.

⚠ DANGER



THROWN OBJECT HAZARD

To prevent serious injury or death:

- Do not operate unless all guards are installed and in good condition.
- Stop blade rotation if bystanders come within several hundred feet.

⚠ WARNING



MOVING PART HAZARD

To prevent serious injury or death from moving parts:

- Close and secure guards and shields before starting.
- Keep hand, feet, hair and clothing away from moving parts.
- Disconnect and lockout power source before adjusting or servicing.
- Do not stand or climb on machine when operating.

⚠ WARNING

To prevent serious injury or death:
Si no lee ingles, pida ayuda a alguien que si lo lee para que le traduzca las medidas de seguridad

- Read and understand Operator's Manual before using. Review annually.
- Do not permit riders on the tractor or mower, including children.
- Do not allow children to operate mower.
- Operate only with guards installed and in good working condition.
- Keep away from moving parts.
- Operate only with tractor equipped with ROPS and seatbelts.
- Before mowing, clear debris from mowing area.
- Do not operate in the raised position.
- Stop engine, lower mower, set brake and wait for all moving parts to stop before dismantling.
- Support mower securely before working beneath unit.
- Transport with clean reflectors, SMV and working lights as required by federal, state, and local laws.
- Keep yourself, others, and clothing away from the rotating POT.
- Keep other away from area to be mowed to avoid injury from flying objects.
- Do not stand between tractor and mower.
- Be careful on uneven terrain. Decrease speed when turning.
- Do not exceed a safe transport speed.

**SHIPPED WITHOUT OIL IN GEAR BOX
AND WITHOUT GREASE IN GREASE FITTINGS.
"CONSULT OWNERS MANUAL FOR
LUBRICATING AND OPERATING INSTRUCTIONS."**

REMEMBER: IF the safety decals have been damaged, removed, become illegible or parts have been replaced without decals, new safety decals must be applied.

TROUBLESHOOTING

PROBLEM	POSSIBLE CAUSE	POSSIBLE REMEDY
Leaves a streak of uncut or partially cut grass	<ol style="list-style-type: none"> 1. Mower not lever side to side 2. Blades dull or bent 3. Carrier ROM too low 4. Field conditions are so wet that the tractor tire is pushing grass into mud 5. Ground speed too fast 6. Blades lock back 7. Blades riding up due to blade bolt wear or loose bolts 8. Grass is down from previous weather conditions 9. Possible build up of material under mower 10. Weed and grass stems are pushed down by tractor tires and do not rebound up so they can be cut. 	<p>Level 3pt Hitch linkage on Tractor. Sharpen or replace blades. Use correct PTO speed too wet to mow. Stop operation and wait until it is drier. Reduce ground speed by shifting to a low gear Free blades Replace Blade Bolts. Mow in only one direction Clean mower Mow again in opposite direction Clean mower. Mow back and forth with enough overlap to mow tire track of previous cut again. Offset mower to left 4-6" by adjusting stabilizer bars. Then mow in counter</p>
Grass cut lower in center of swath than at edge	Height of mower lower at rear or front	Adjust mower height and altitude so that mower rear and front are within 1/2" of same height.
Gearbox Overheating	<ol style="list-style-type: none"> 1. Low on lubricant. 2. Improper type of lubricant 3. Excessive trash build-up 	<p>Fill to proper level. Replace with proper lubricant Remove trash around gearbox</p>
Blade is scalping ground.	<ol style="list-style-type: none"> 1. Mower too low 2. Field is ridged 3. Field is too wet 	<p>Raise mower and 3-pt. Control stop. Cut field at a different angle. Stop and wait until it is drier.</p>
Mower will not cut. (Shear bolt drive only)	Shear bolt sheared	Install new shear bolt.
Mower will not cut all the same	Slip clutch slipping.	Adjust slip clutch according instructions
Mower moves from side to side when cutting	Loose tractor sway chains or bars, or sway blocks improperly installed	Adjust sway chains, bars or sway blocks.
PTO contacts cutter front frame when raised	Raising mower too high or incorrect adjustment of Tractor Top Link	Adjust top link or tractor lift stops (see attachment)
Blade bolts come loose	<ol style="list-style-type: none"> 1. Bolts not tightened 2. Bolts hole elongated or oversized 3. Blade bolt threads are worn or damaged 	<p>Tighten bolts to 350 ft/lb. Replace blade carrier Replace blade bolt, lock washer and nut</p>
Blade wears too fast	<ol style="list-style-type: none"> 1. Cutting in sandy conditions 2. Cutting in rocky conditions 3. Blades hitting ground 	Increase cutting height
Mower seems to require excessive power	<ol style="list-style-type: none"> 1. Advancing into grass or brush too rapidly 2. Hitting ground 3. Worn or dull blades 4. Tractor not large enough 	<p>Reduce forward travel speed Raise mower Sharpen or replace blades Use larger horsepower tractor</p>

PROBLEM	POSSIBLE CAUSE	POSSIBLE REMEDY
Excessive Vibration	<ol style="list-style-type: none"> 1. Check gearbox bolts 2. Check for loose nuts on 3. Check if output shafts is bent, oil will normally leak from bottom seal 4. Check if blades are free-swinging 5. Check for even wear on each blade tip, where both blades changed at the same time? 6. Blade Broken 7. Blade beam bent 8. New blade or bolts marched with worn blade or bolts 9. Drivelines not phased correctly implement and tractor yokes must be in line 10. Wire or rope wrapped around blade beam 11. Blades worn and are out of balance 	<p>Tighten if loose</p> <p>Tighten if loose</p> <p>Replace shaft is bent</p> <p>Free blades so they swing</p> <p>Weight blades, they should be within 1 oz, always replace both blades</p> <p>Replace blades, in sets</p> <p>Replace blade beam</p> <p>Replace blades or bolts in sets</p> <p>Replace driveline</p> <p>Remove wire or rope</p> <p>Replace blades set</p>
Gearbox noisy	<ol style="list-style-type: none"> 1. Rough gears 2. Worn bearings 3. Low oil in gearbox 4. Damaged oil seal 5. Bent shaft 6. Shaft rough in oil seal area 7. Oil seal installed wrong 8. Oil seal not sealing in the housing 9. Oil level too high 10. Hole in gearbox 11. Gasket damaged 12. Bolts loose 	<p>Run in or change gears</p> <p>Replace bearing</p> <p>Check level and add oil</p> <p>Replace seal</p> <p>Replace oil seal and shaft</p> <p>Replace or repair shaft</p> <p>Replace seal</p> <p>Replace seal or use a sealant</p> <p>On outside outside diameter of seal</p> <p>Drain oil to proper level</p> <p>Replace gearbox</p> <p>Replace gasket</p> <p>Tighten bolts</p>
Front hitch "A" frame gending sideways	<ol style="list-style-type: none"> 1. Operator turning sharply hitting objects with tailwheel frame or mower deck 2. Mower is being operated to low and mower deck is contanting ground during turns 3. Tractor 3pt hitch leaking down and mower deck is contracting ground 	<p>Drive carefully and plan turns to avoid hitting buildings, post, trees, etc.</p> <p>Raise mower (specially on rough ground), set stop on hitch controls lever so hitch lit arms do not drop mower on ground.</p> <p>Repair tractor hitch hydraulic system.</p>

EXPLODED VIEW & PARTS LIST

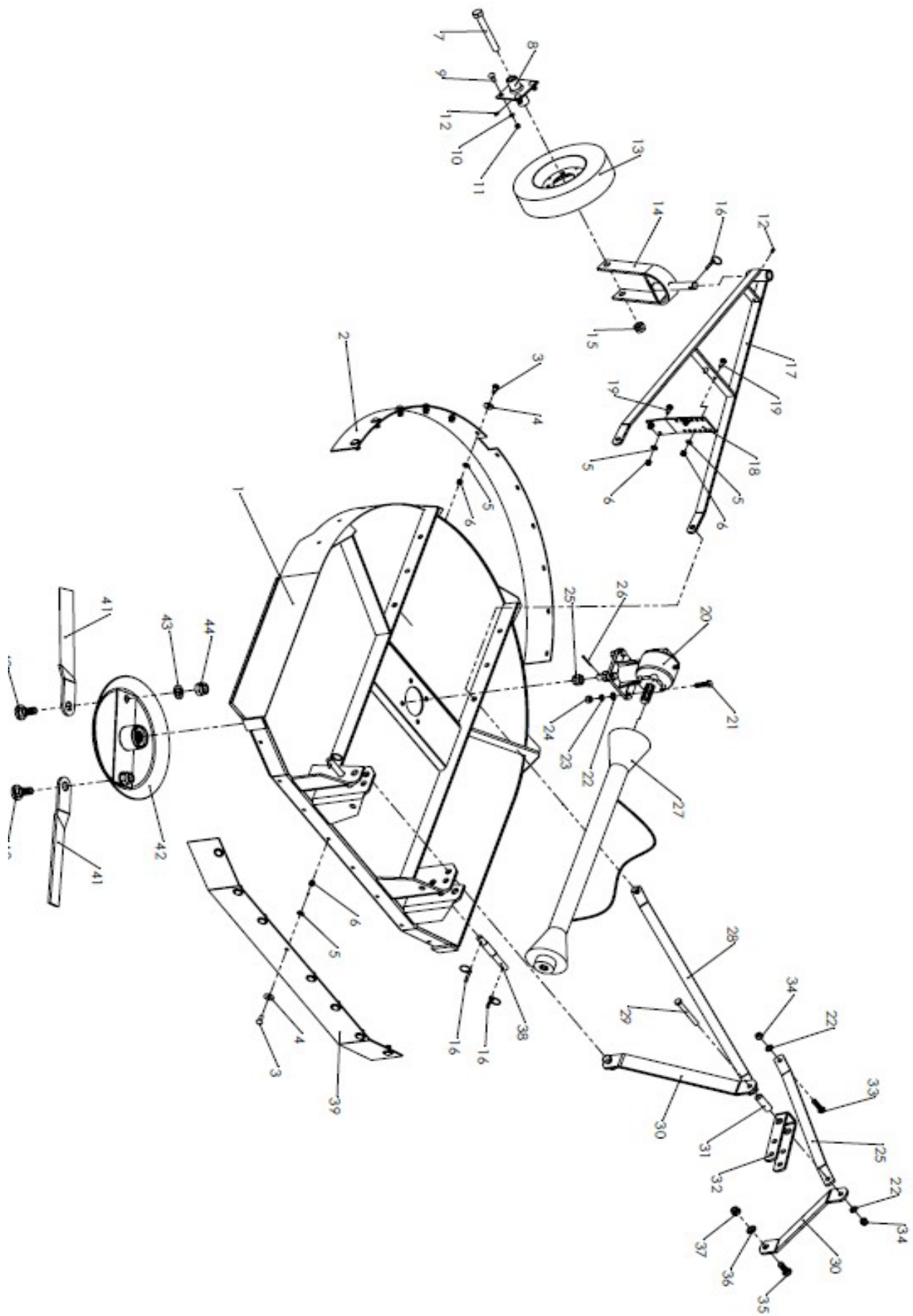

REF	PART NO	DESCRIPTION	QTY
1	360001	Main deck	1
2	360002	Rear rubber guard	1
3	363503	M10x25 Round head carriage bolt	18
	360403		18
	360503		20
	360603		21
4	363504	Ø12 Large Washer	18
	360404		18
	360504		20
	360604		21
5	363505	Ø Flat Washer	22
	360405		22
	360505		24
	360605		25
6	363506	M10 Lock nut	22
	360406		22
	360506		24
	360606		25
7	360007	M24 x 180 Hex bolt	1
8	360008	Spindle Assembly	1
9	360009	M12 x 30 Round head carriage bolt	4
10	360010	Ø12 Flat washer	4
11	360011	M12 Lock nut	4
12	360012	M8 Grease fitting	2
13	360013	Wheel	1
14	360014	Wheel fork	1
15	360015	M24 Nut	1
16	360016	Ø8 Lynch pin	3

REF	PART NO	DESCRIPTION	QTY
17	360017	A frame	1
18	360018	Height adjustment bar	1
19	360019	M10 x 30 Round head carriage bolt	4
20	360020	Gear box	1
21	360021	M16 x Hex bolt	4
22	360022	Ø16 Flat washer	7
23	360023	Ø16 Lock washer	4
24	360024	M16 Nut	4
25	360025	M24 Hex castle nut	1
26	360026	Cotter pin	1
27	360027	PTO Driveline	1
28	360028	Rear brace	2
29	360029	M16 x 140 Hex bolt	1
30	360030	Front brace	2
31	360031	Steel sleeve	1
32	360032	U Bracket	1
33	360033	M16 x 55 Hex bolt	2
34	360034	M16 Lock nut	3
35	360035	M20 x 45 Hex bolt	2
36	360036	Ø20 Flat washer	2
37	360037	M20 Lock nut	2
38	360038	Pin	2
39	360039	Front rubber guard	1
40	360040	M27 Bolt for fastenning blade	2
41	360041	Blade	2
42	360042	Blade holder	1
43	360043	Ø27 Flat washer	2
44	360044	M27 Nut	2



BRABEREQ.COM
WGSALES@BRABEREQ.COM

PHONE: 604-850-7770
FAX: 604-850-7774
TOLL FREE PHONE: 1-877-588-3311
TOLL FREE FAX: 1-800-665-7334